

ITEM NO.	PART NUMBER	DESCRIPTION	QTY.
1	BSPN-0412V2-A2		1
2	BSPN-0412V2-A1		1
3	BSPN-0412-A3		2
4	BSPN-0412-A4		1
5	BSPN-0412-H1		2
6	BSPN-0412-A5		1
7	BSP-F8DIN5685C	Standard chain DIN5685C-f8mm	1
8	SP21603	Standard part	2
9	BSP-DIN5299-27001B	Standard part DIN5299B-f4mm	3
10	BSP-DIN11024-27524	Standard part	3
11	BSP-F4DIN5685A	Standard chain DIN5685A-f4mm	1

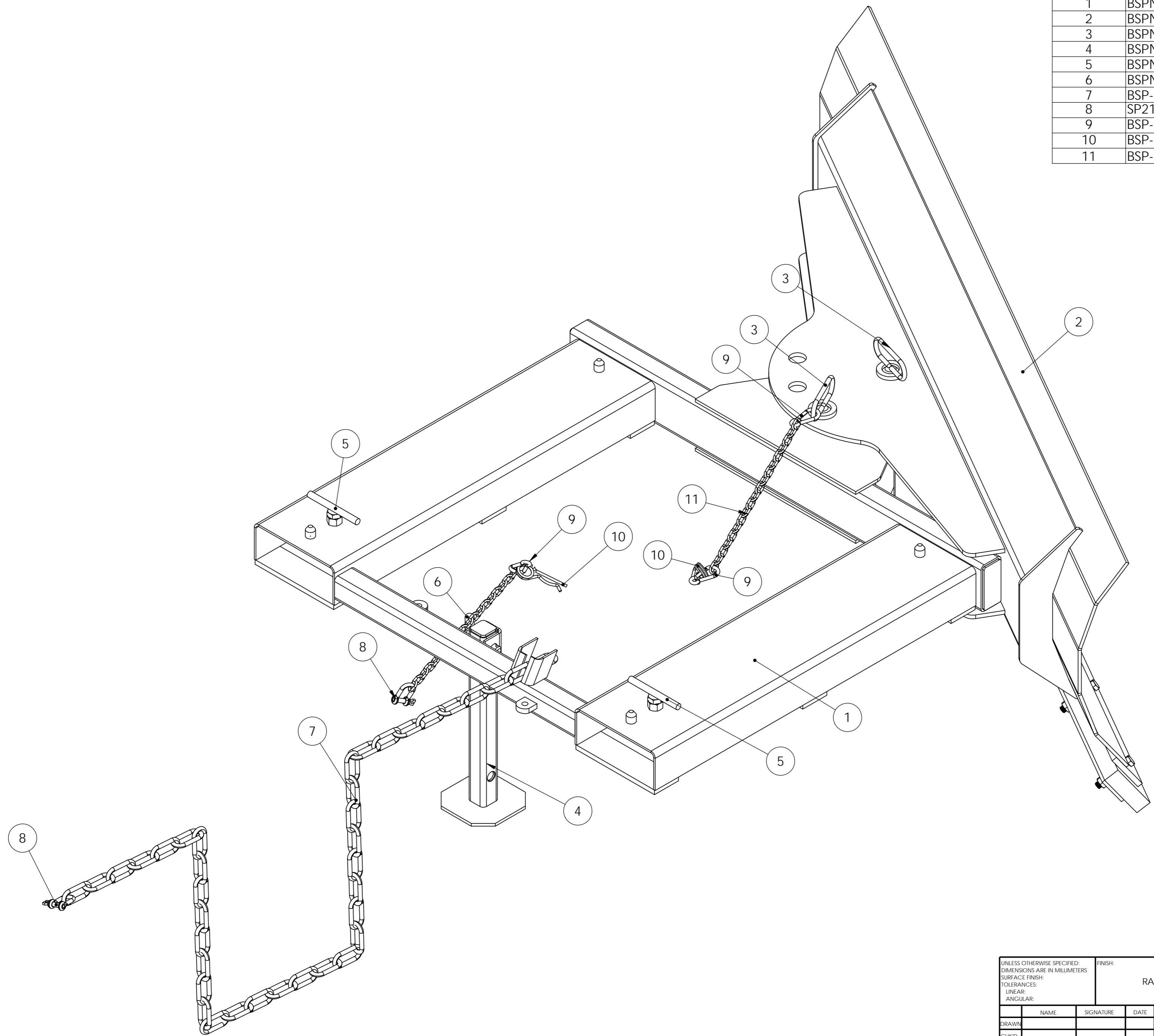

UNLESS OTHERWISE SPECIFIED: DIMENSIONS ARE IN MILLIMETERS SURFACE FINISH: TOLERANCES: LINEAR: ANGULAR:				FINISH: RAL 3000		DEBUR AND BREAK SHARP EDGES		DO NOT SCALE DRAWING		REVISION	
DRAWN				NAME		SIGNATURE		DATE		TITLE:	
CHK'D											
APP'VD											
MFG											
Q.A										MATERIAL:	
										DWG NO. BSPN-0412	
										SCALE:1:20	
										WEIGHT: 173.84	
										SHEET 1 OF 4	

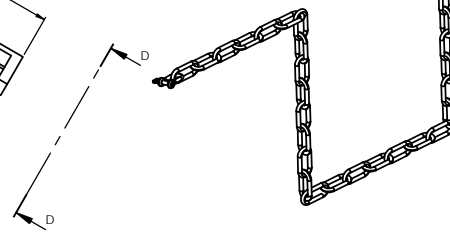
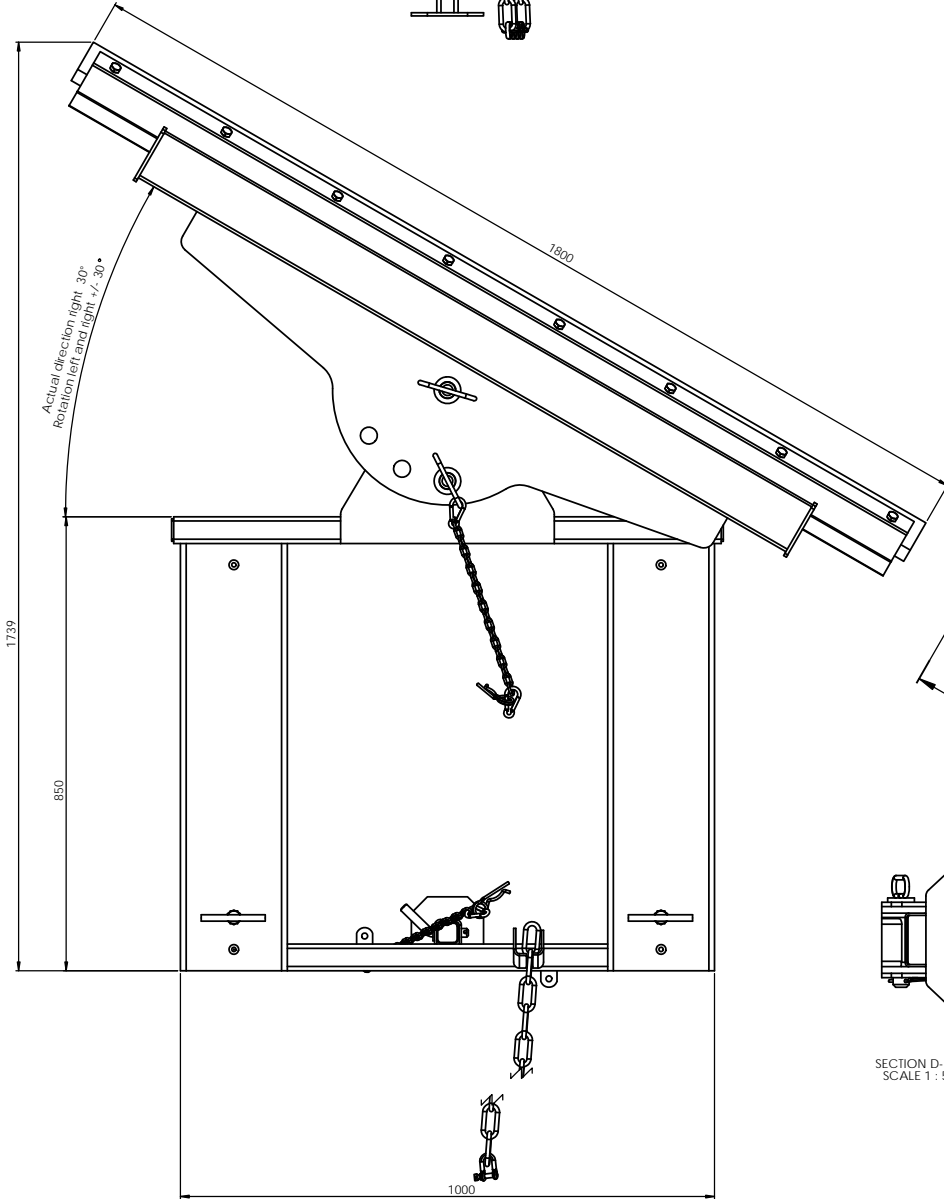
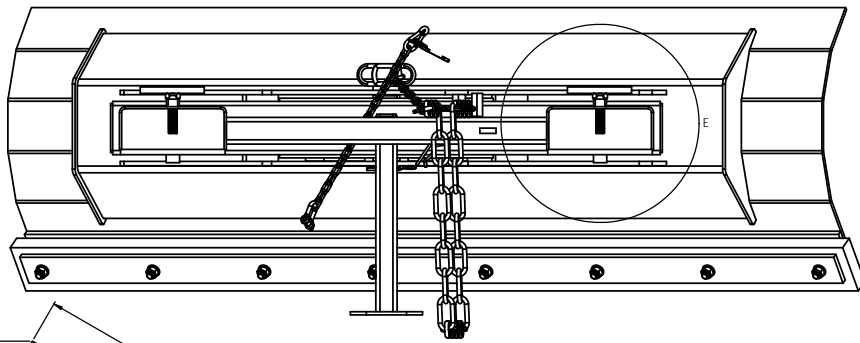

SECTION D-D
SCALE 1 : 5

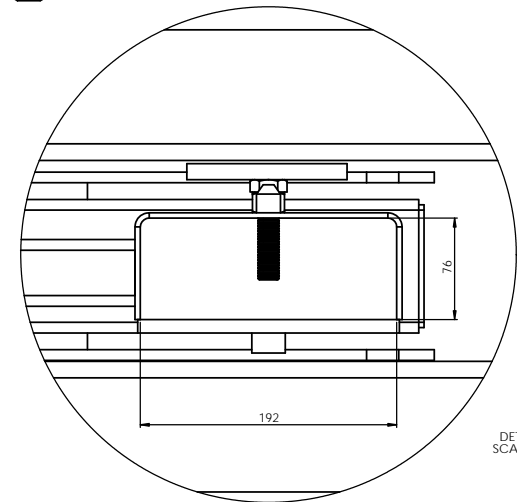
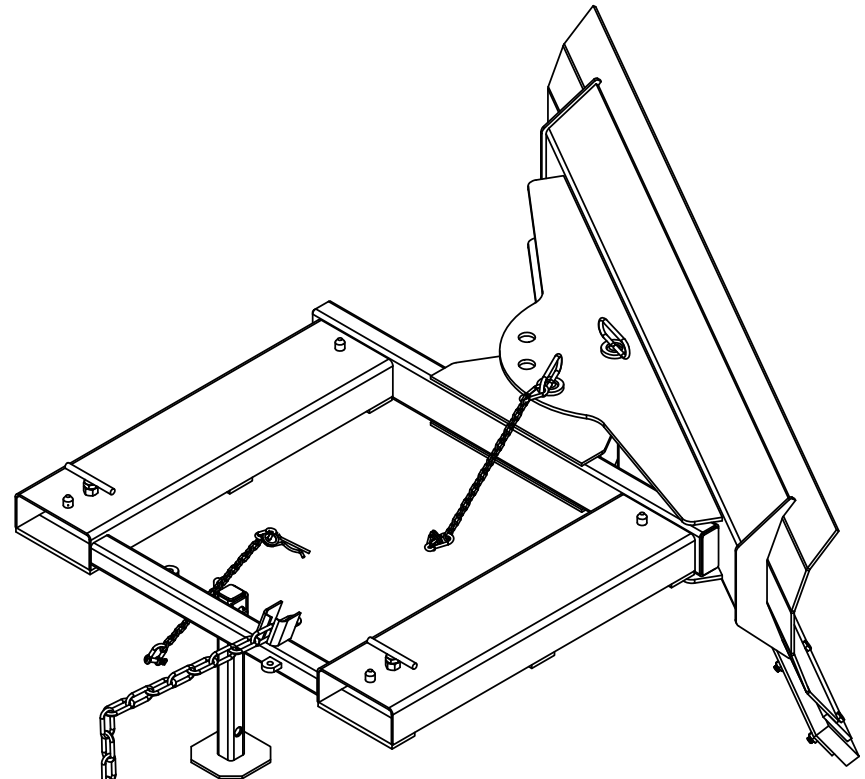
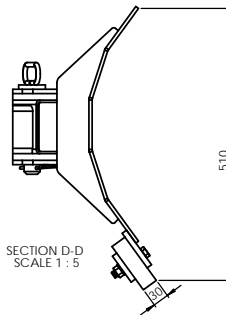

DETAIL E
SCALE 1 : 2

DESIGNER: [] CHECKED: [] DATE: []		MATERIAL: RAL 3000	FINISH: POLYESTER POWDER COATING	DRAWING NO.: BSPN-0412	SCALE: 1:1	SHEET NO.: 1 OF 1
NAME: []	SIGNATURE: []	DATE: []	TITLE: []	PROJECT: []	DRAWN BY: []	CHECKED BY: []

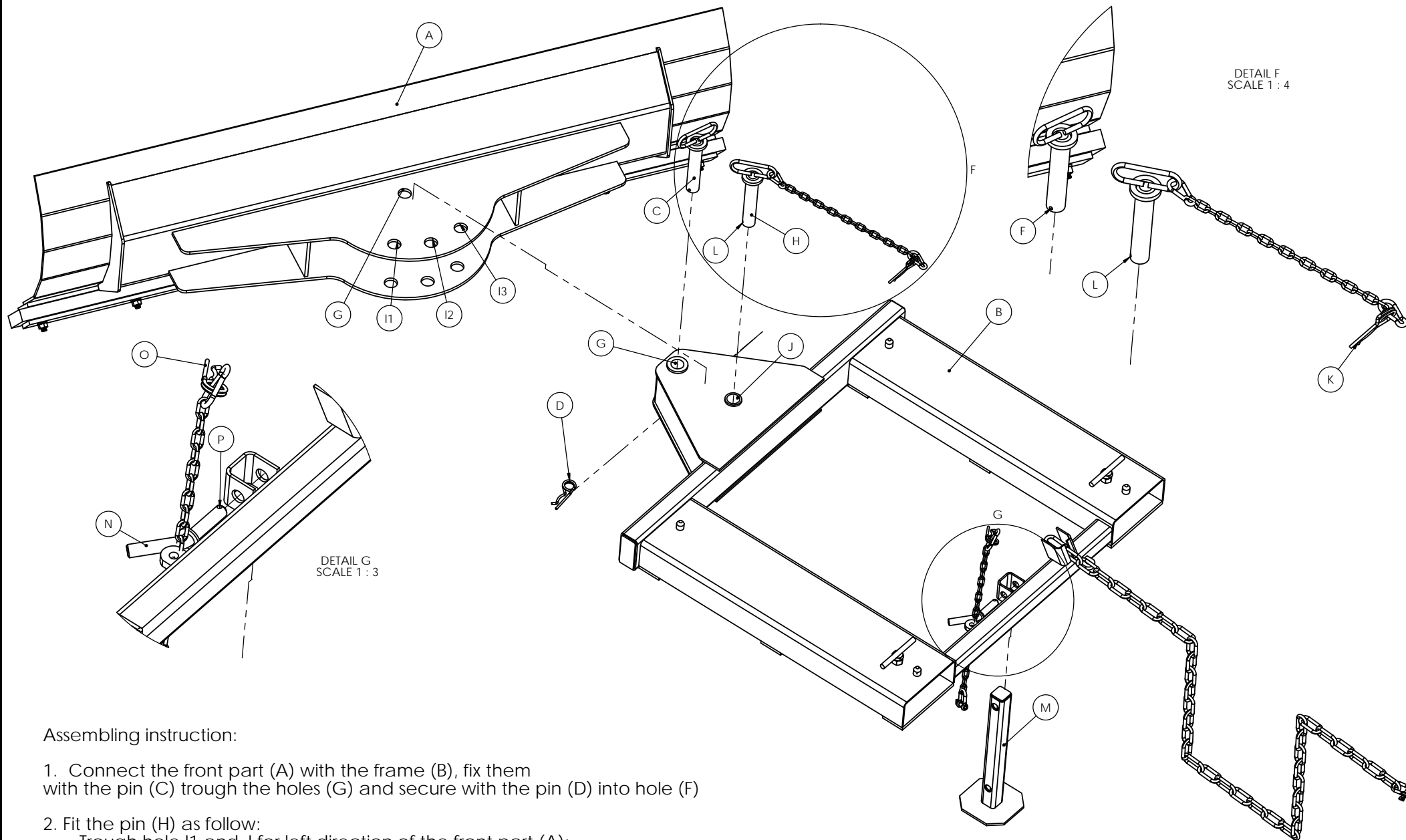

DETAIL F
SCALE 1 : 4

DETAIL G
SCALE 1 : 3

Assembling instruction:

1. Connect the front part (A) with the frame (B), fix them with the pin (C) trough the holes (G) and secure with the pin (D) into hole (F)
2. Fit the pin (H) as follow:
 - Trough hole I1 and J for left direction of the front part (A);
 - Trough hole I2 and J for straight position;
 - Trough hole I3 and J for right direction of the front part (A);
 and secure with the pin (K) trough hole (L)
3. Fit the leg (M) with the frame (B), fix with the pin (N) and secure with the pin (O) trough the hole (P)

UNLESS OTHERWISE SPECIFIED: DIMENSIONS ARE IN MILLIMETERS SURFACE FINISH TOLERANCES: IT12 LINEAR ANGULAR:			FINISH RAL 3000	DEBUR AND BREAK SHARP EDGES	DO NOT SCALE DRAWING	REVISION:
NAME	SIGNATURE	DATE			TITLE:	
DRAWN						
CHECKED						
APPROVED						
MFG						
QA				MATERIAL	DWG NO.	A2
				WEIGHT: 173.84	SCALE: 1:20	SHEET 3 OF 4

BSPN-0412

A2

Left direction

Straight position

Right direction

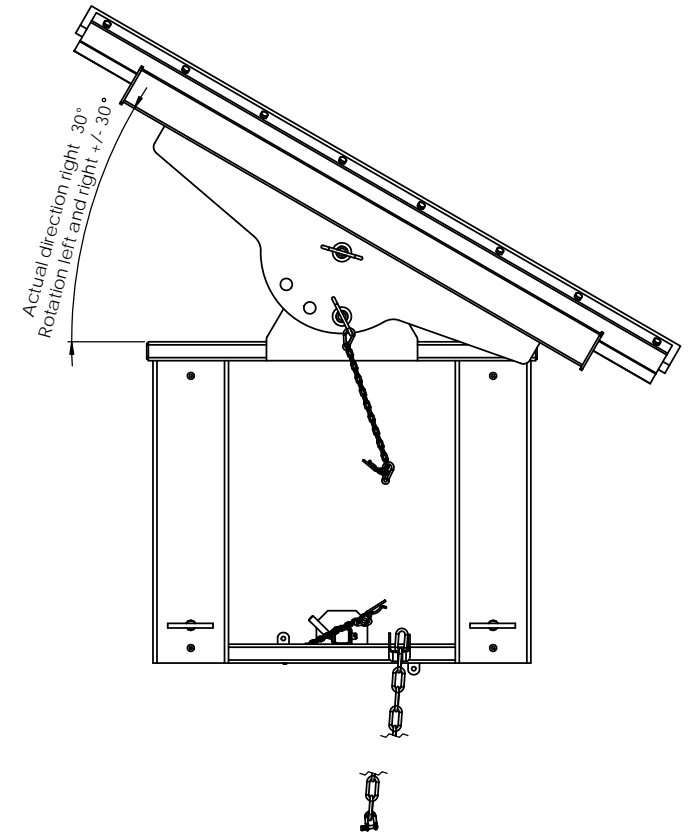
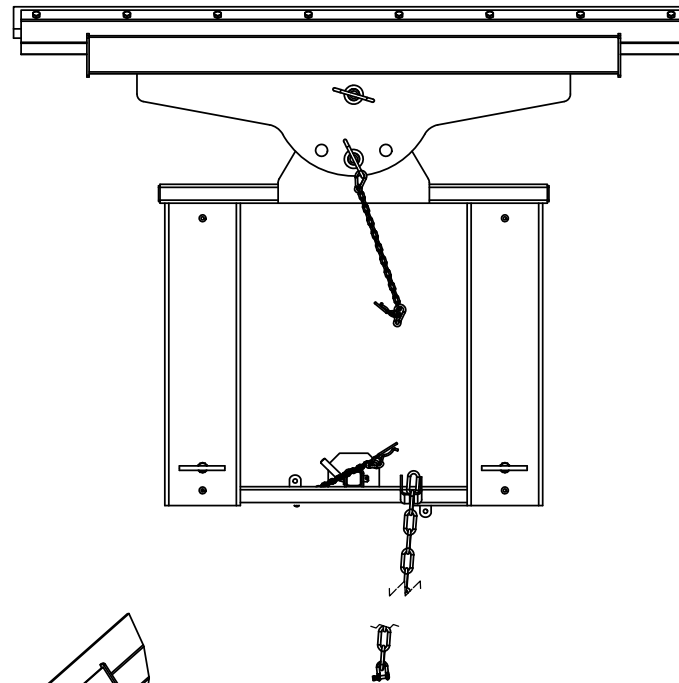
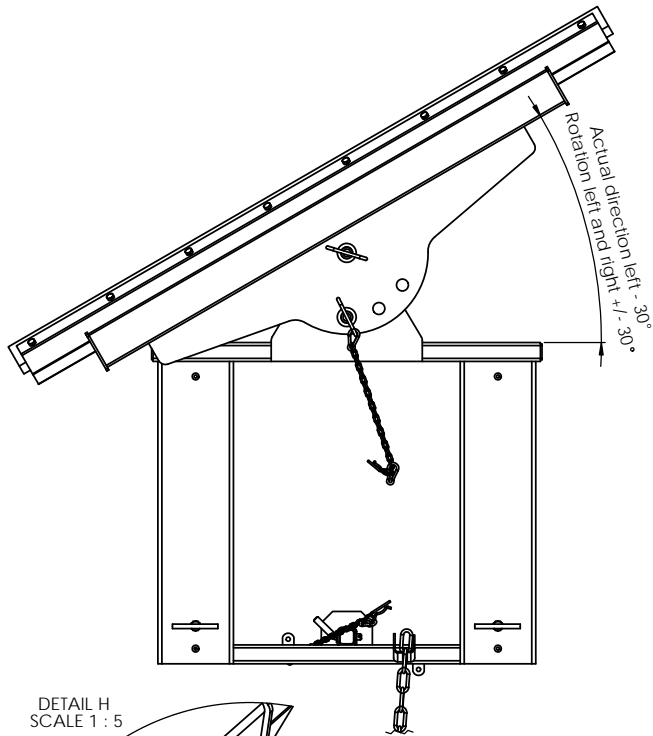

DETAIL H
SCALE 1 : 5

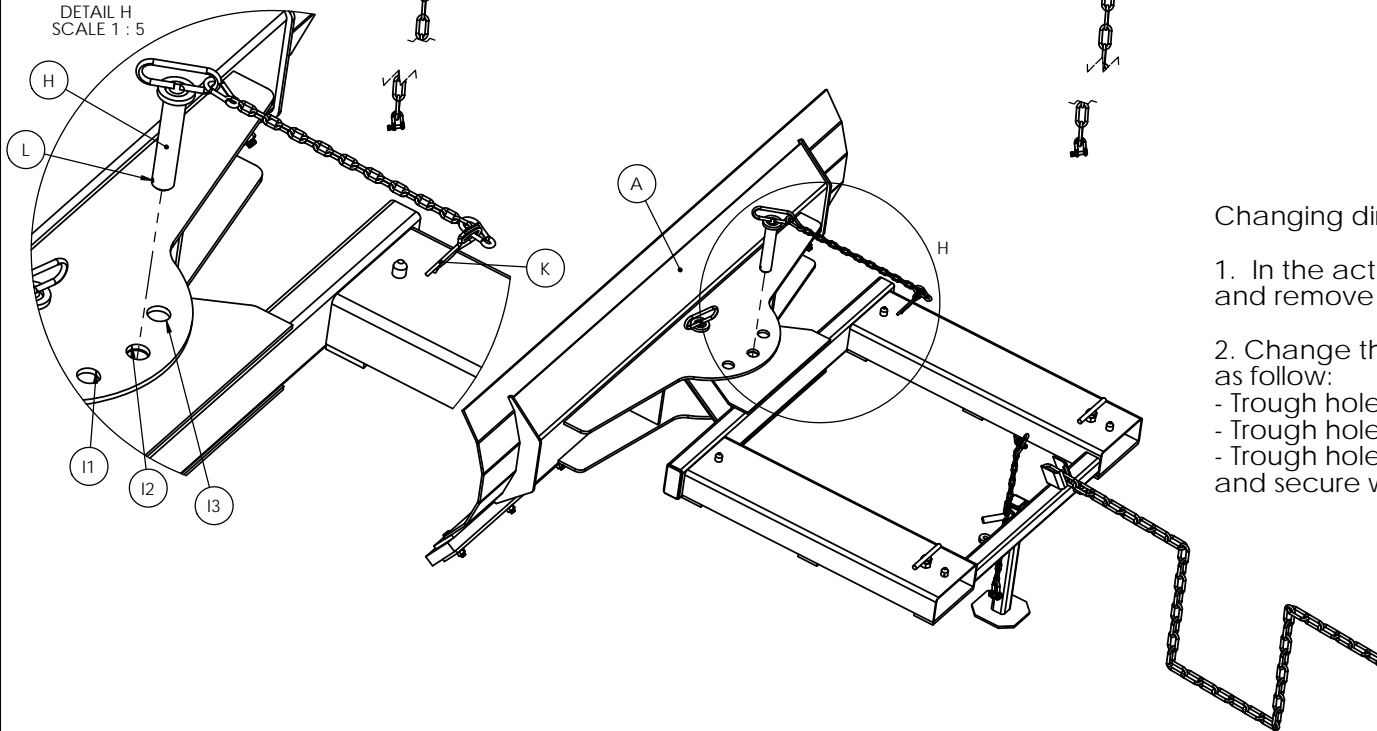

Changing direction:

1. In the actual position, remove the security pin (k) from the hole (L), and remove the pin(H)
2. Change the direction of the front part (A) and Fit the pin (H) as follow:
 - Trough hole I1 for left direction of the front part (A);
 - Trough hole I2 for straight position;
 - Trough hole I3 for right direction of the front part (A);
 and secure with the pin (K) trough hole (L)

UNLESS OTHERWISE SPECIFIED: DIMENSIONS ARE IN MILLIMETERS		FINISH	RAL 3000		DEBUR AND BREAK SHARP EDGES	DO NOT SCALE DRAWING	REVISION
SURFACE FINISH TOLERANCES: IT12		LINEAR					
ANGULAR							
NAME	SIGNATURE	DATE			TITLE		
DRAWN							
CHECKED							
APPV'D							
MFG							
D.A.			MATERIAL		DWG NO.		A2
					BSPN-0412		
			WEIGHT: 173.84		SCALE: 1:20		SHEET 4 OF 4

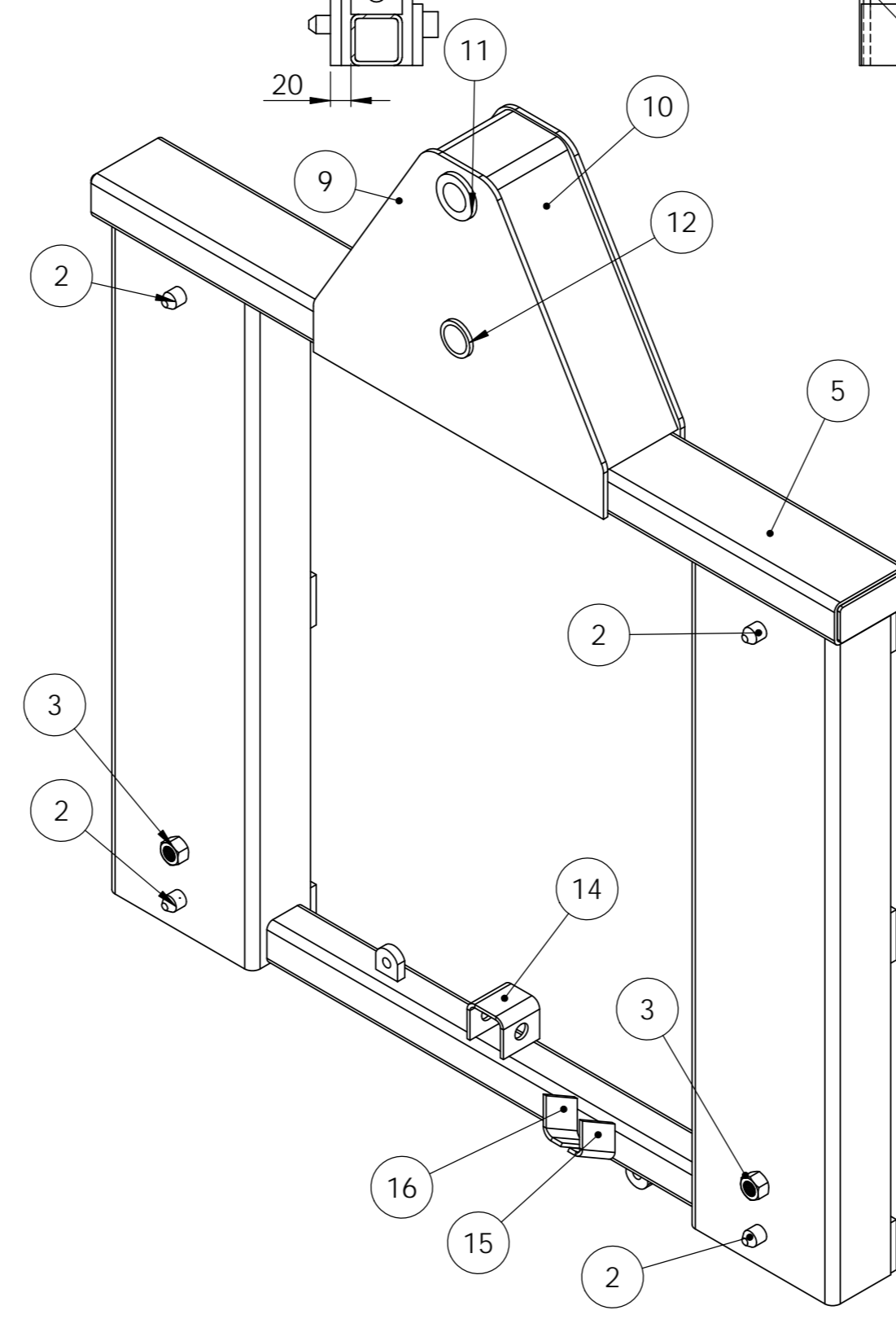
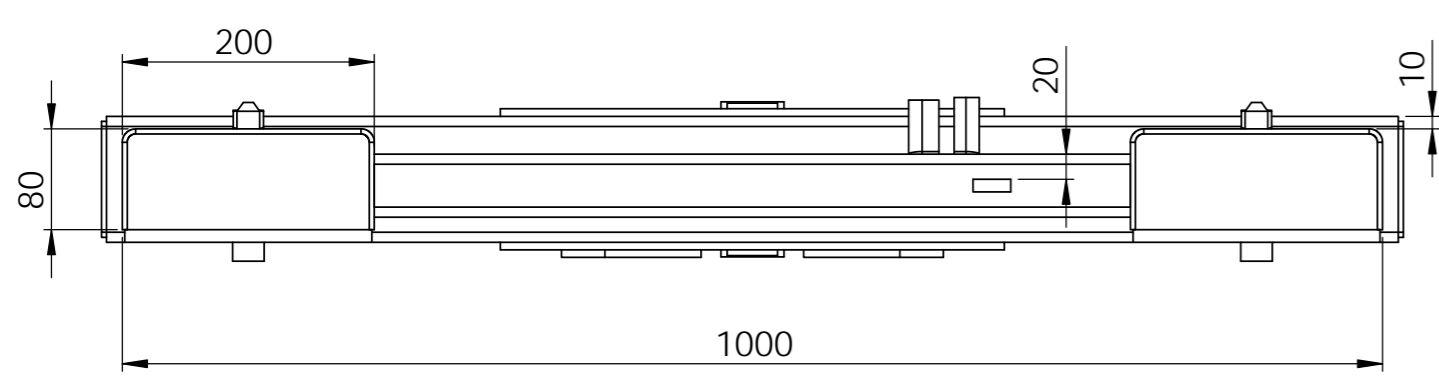
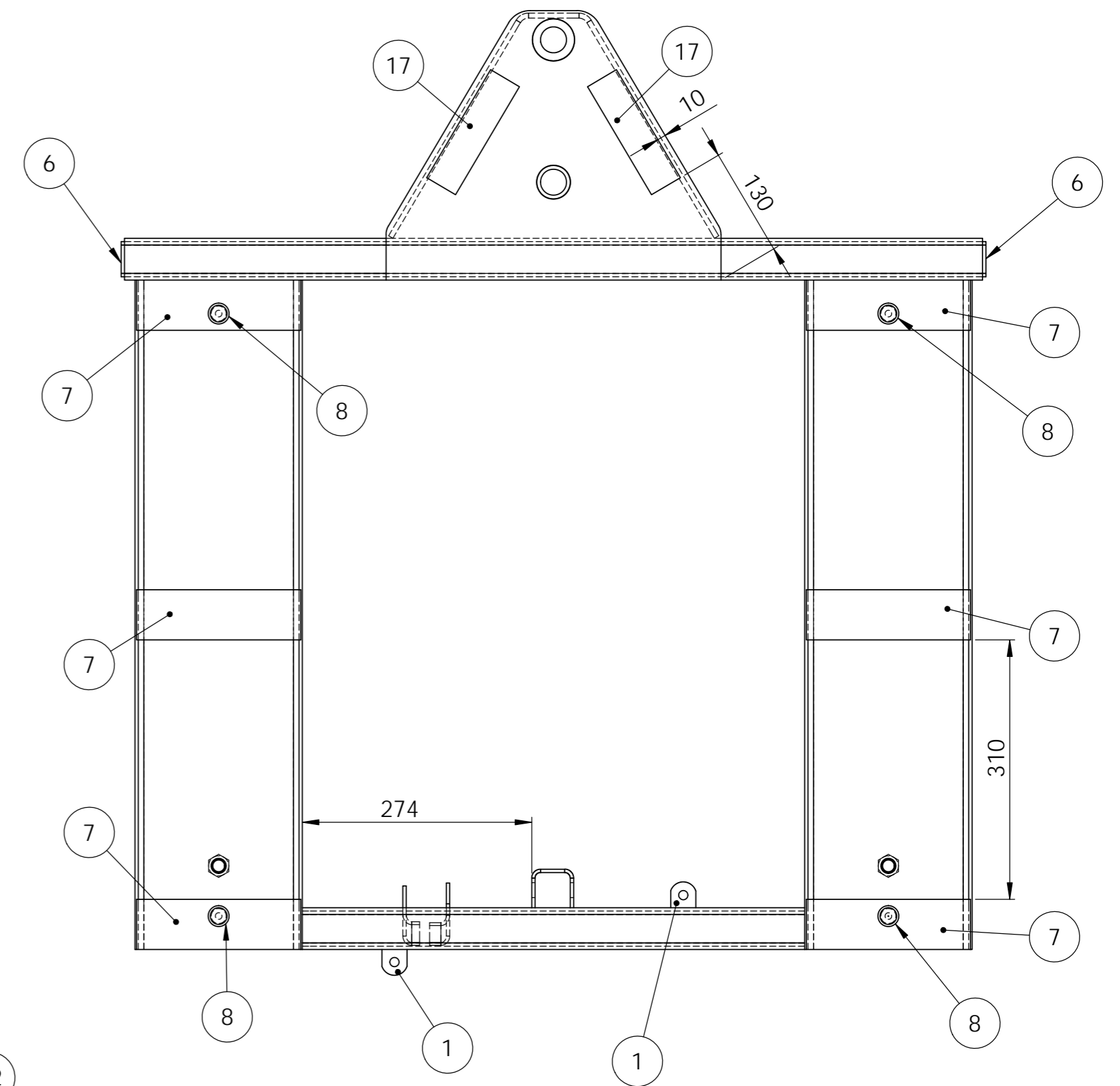
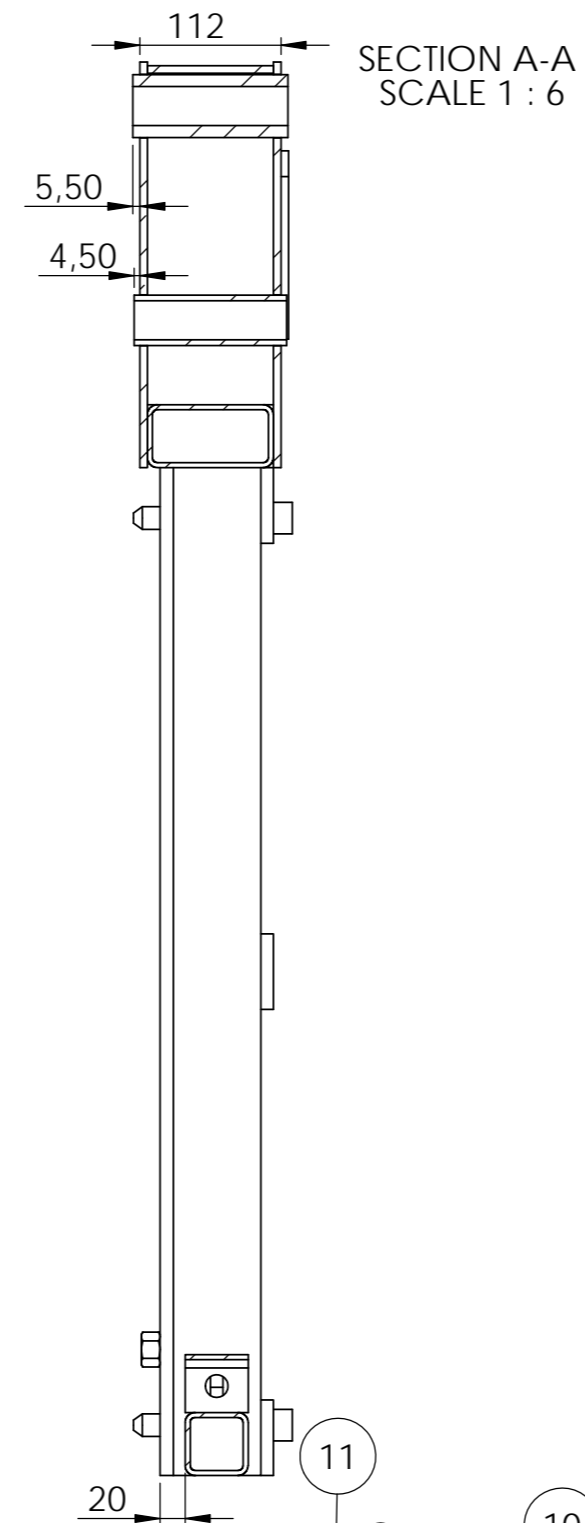
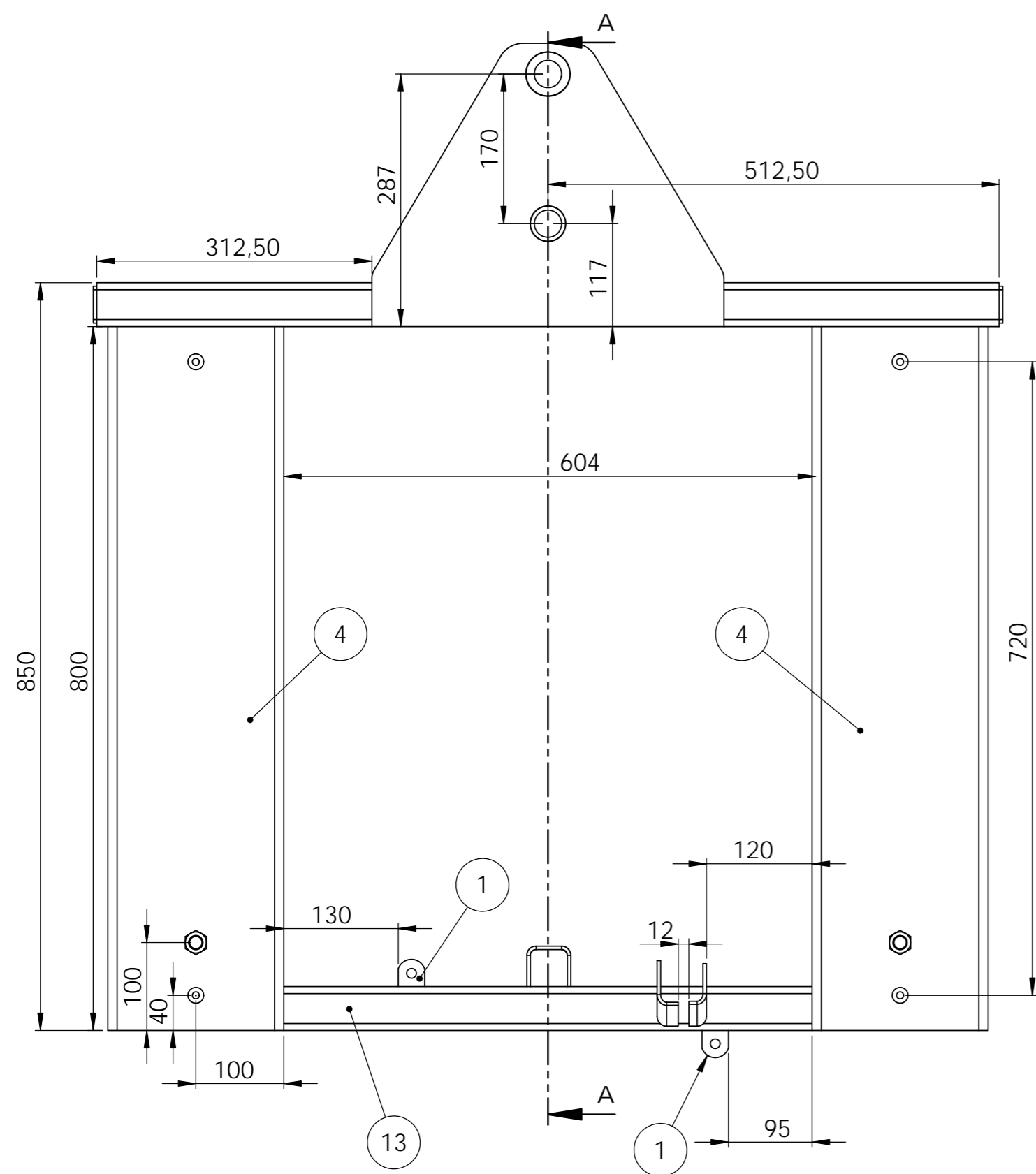

ITEM NO.	PART NUMBER	DESCRIPTION	QTY.
1	BSPN-0412-20		2
2	BSPN-0412-13		4
3	Hexagon Nut ISO 4032 - M16		2
4	BSPN-0412-09		2
5	BSPN-0412-10		1
6	BSPN-0412-11		2
7	BSPN-0412-12		6
8	BSPN-0412-14		4
9	BSPN-0412V2-15		2
10	BSPN-0412V2-16		1
11	BSPN-0412-17		1
12	BSPN-0412-18		1
13	BSPN-0412-19		1
14	BSPN-0412-21		1
15	BSPN-0412-22		1
16	BSPN-0412-23		1
17	BSPN-0412-31		2

UNLESS OTHERWISE SPECIFIED:
 DIMENSIONS ARE IN MILLIMETERS
 SURFACE FINISH:
 TOLERANCES: IT12
 LINEAR:
 ANGULAR:

FINISH: RAL 3000 powder coated

DEBUR AND BREAK SHARP EDGES

DO NOT SCALE DRAWING

REVISION

TITLE:

DRAWN: _____

CHK'D: _____

APP'VD: _____

MFG: _____

Q.A: _____

MATERIAL:

WEIGHT: 48.99

DWG NO: **BSPN-0412V2-A2**

SCALE: 1:10

SHEET 1 OF 3

A2

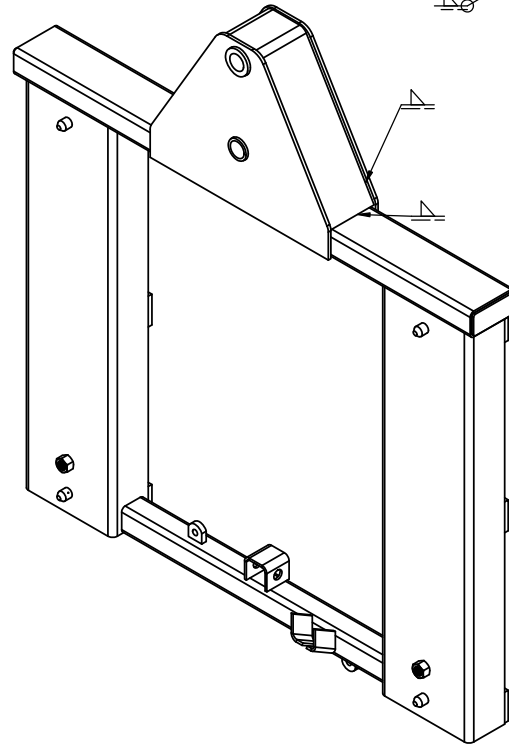
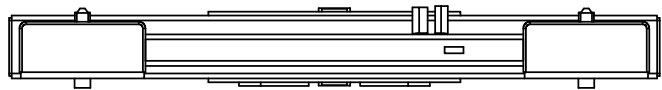
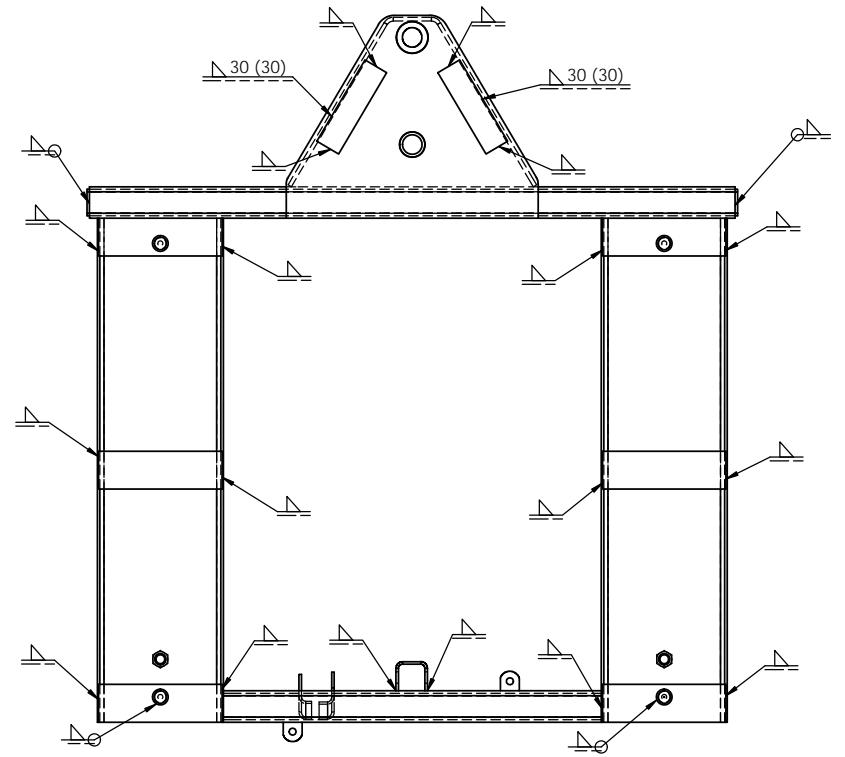
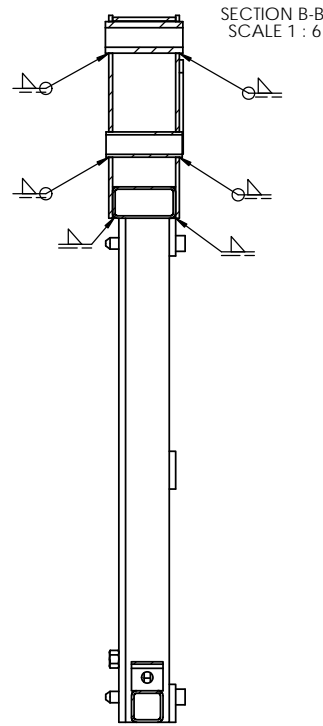
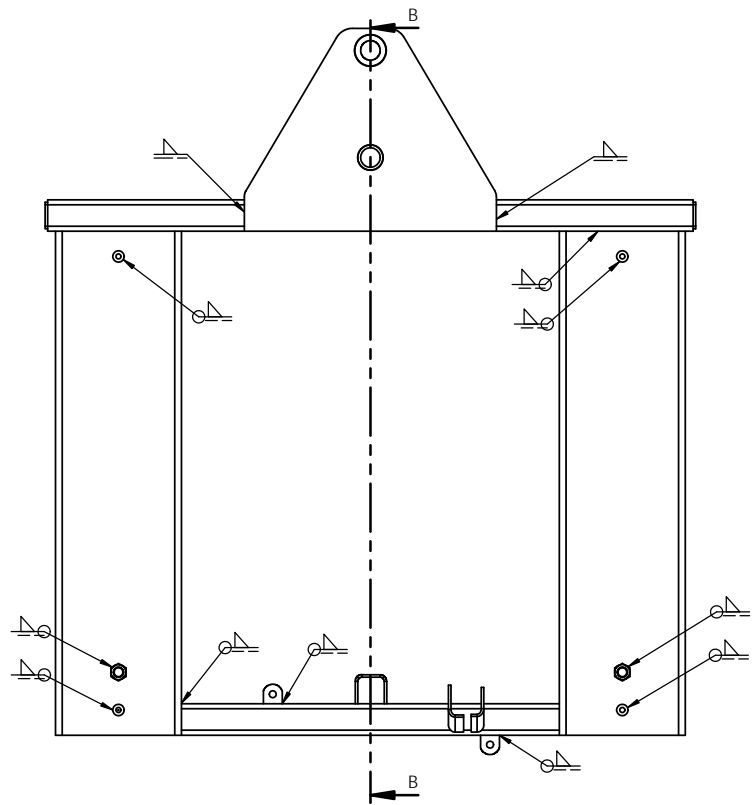

UNLESS OTHERWISE SPECIFIED: DIMENSIONS ARE IN MILLIMETERS SURFACE FINISH TOLERANCES: IT12 LINEAR ANGULAR:		FINISH RAL 3000 powder coated	DEBUR AND BREAK SHARP EDGES	DO NOT SCALE DRAWING	REVISION
NAME	SIGNATURE	DATE		TITLE:	
DRAWN					
CHECKED					
APPROVED					
MFG					
D.A.			MATERIAL	DWG NO: BSPN-0412V2-A2 A2	
			WEIGHT: 45.99	SCALE: 1:10	SHEET 2 OF 3

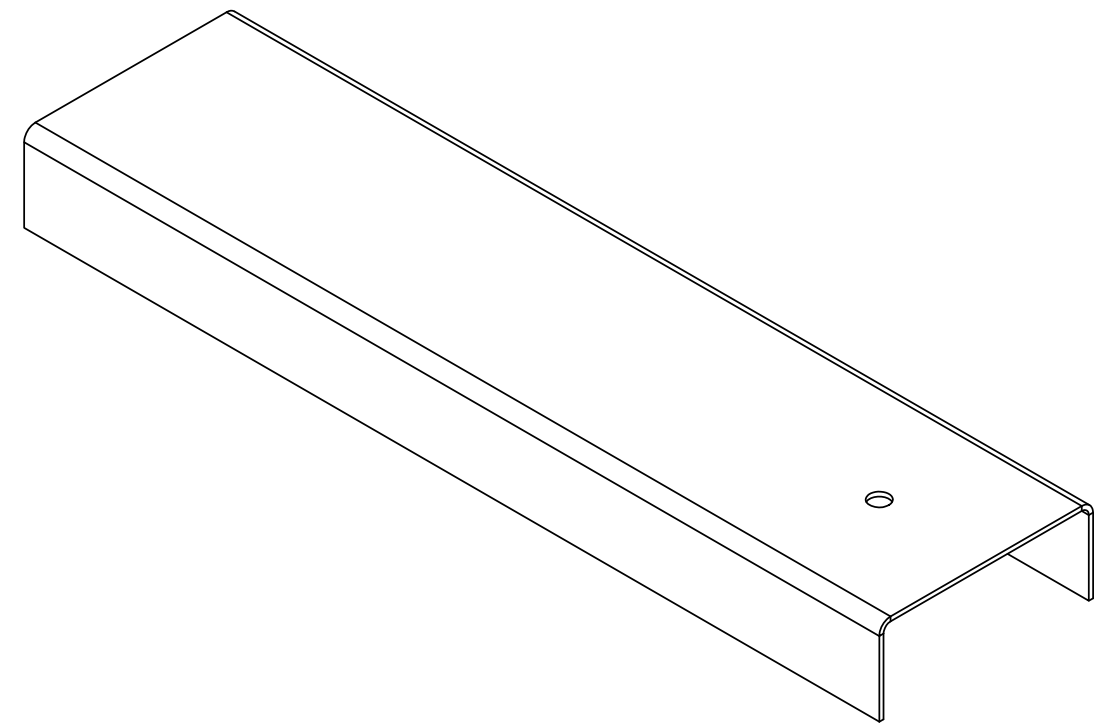
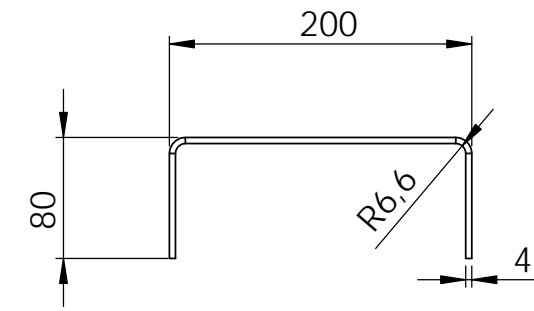
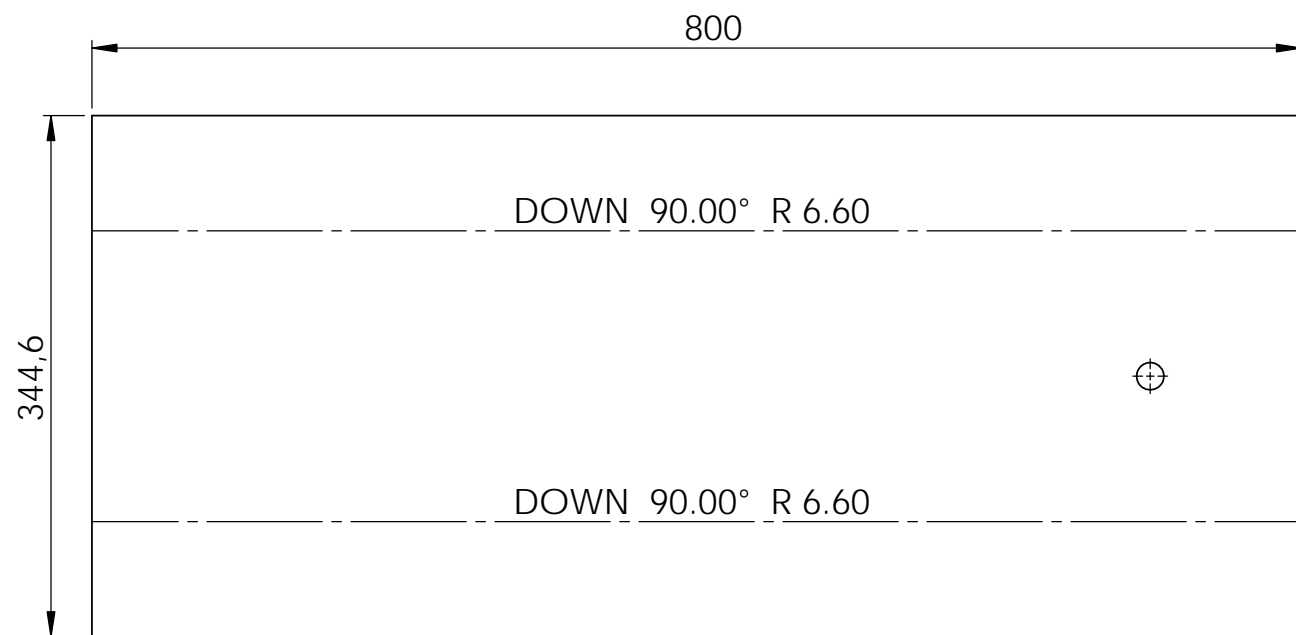
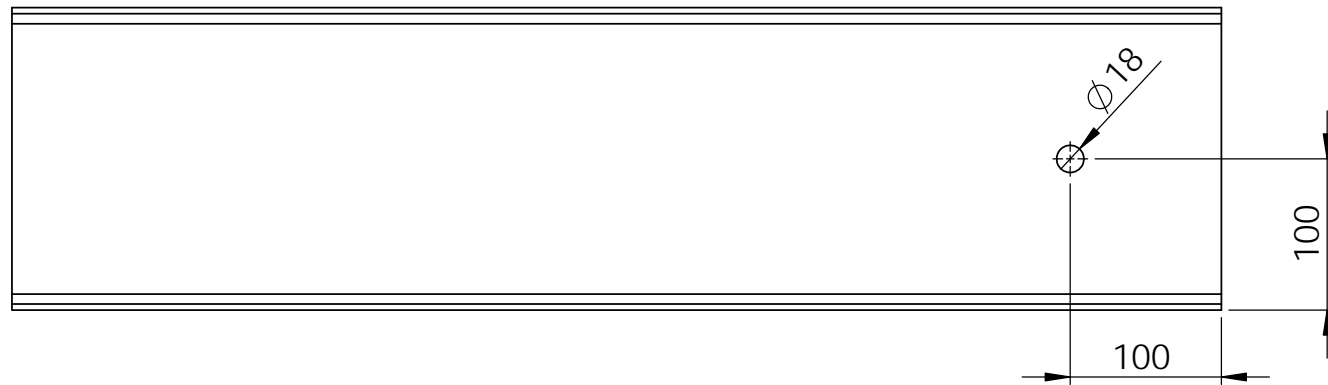
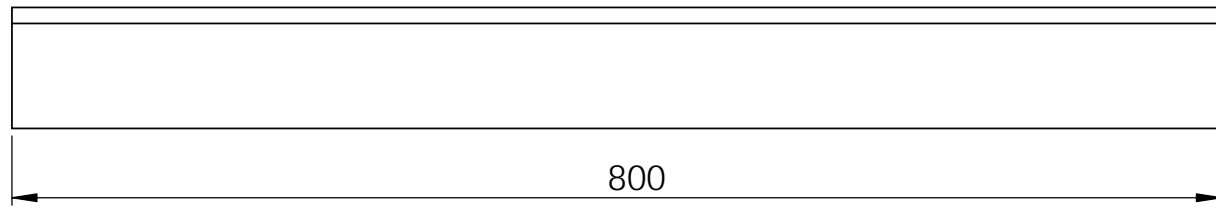

UNLESS OTHERWISE SPECIFIED: DIMENSIONS ARE IN MILLIMETERS SURFACE FINISH: TOLERANCES: LINEAR: ANGULAR:				FINISH:		DEBUR AND BREAK SHARP EDGES		DO NOT SCALE DRAWING		REVISION	
DRAWN				SIGNATURE		DATE		TITLE:			
CHK'D											
APPV'D											
MFG											
Q.A						MATERIAL:		DWG NO.		A3	
						1.0037 (S235JR)		BSPN-0412-09			
						WEIGHT: 8.59		SCALE:1:10		SHEET 1 OF 1	

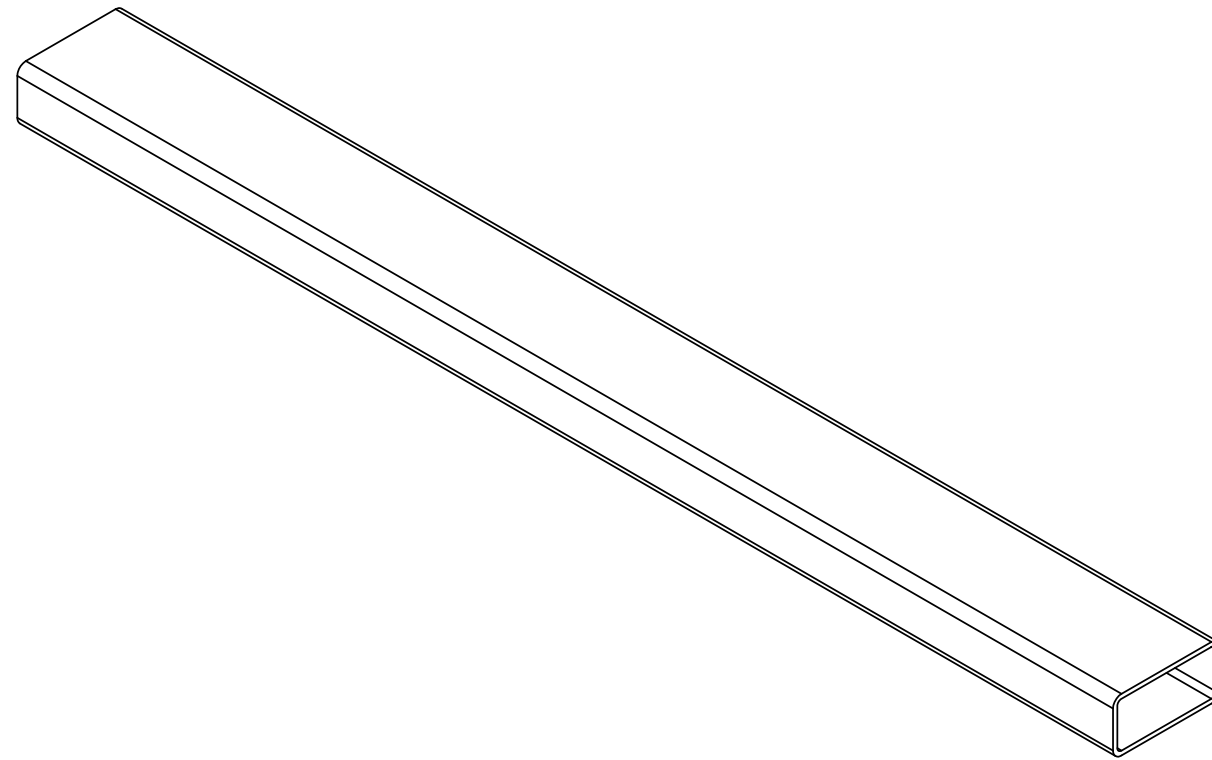
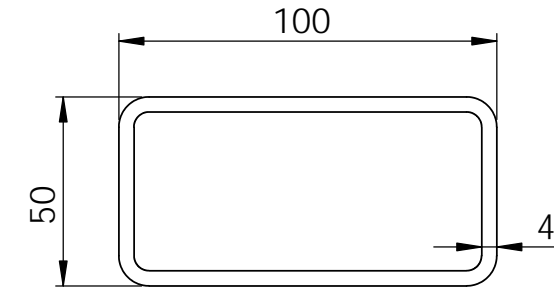
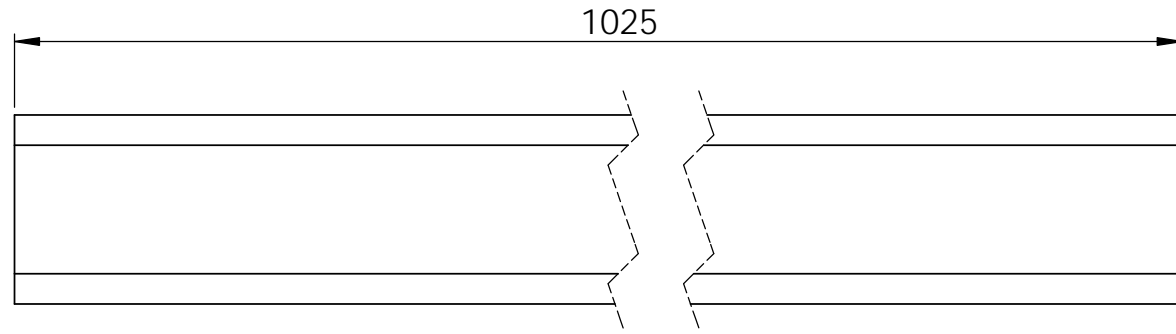

UNLESS OTHERWISE SPECIFIED: DIMENSIONS ARE IN MILLIMETERS SURFACE FINISH: TOLERANCES: IT12 LINEAR: ANGULAR:				FINISH:		DEBUR AND BREAK SHARP EDGES		DO NOT SCALE DRAWING		REVISION	
								TITLE:			
DRAWN	NAME	SIGNATURE	DATE					DWG NO. BSPN-0412-10			
CHK'D											
APPV'D											
MFG											
Q.A											
				MATERIAL: 1.0037 (S235JR)				SCALE:1:5		A3	
				WEIGHT: 8.75				SHEET 1 OF 1			

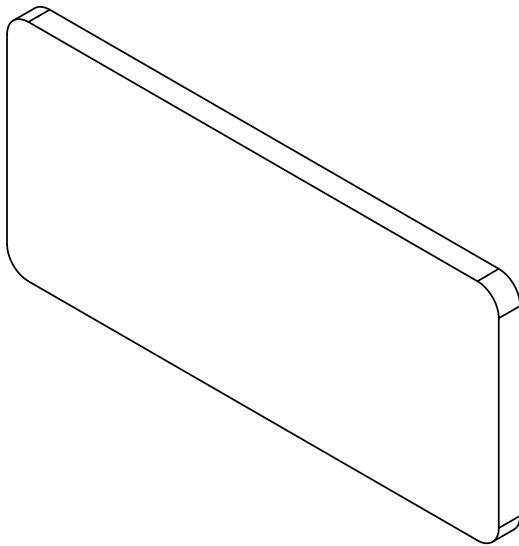
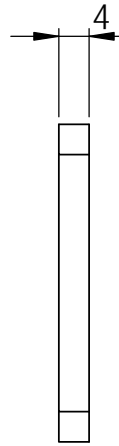
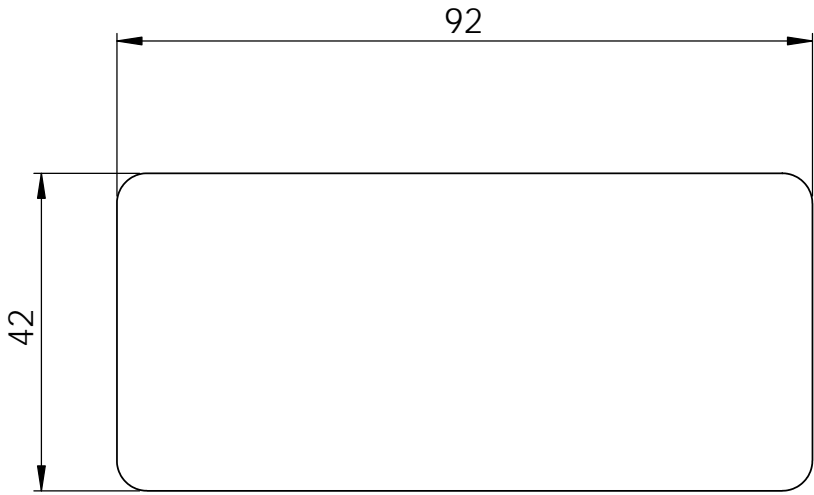

UNLESS OTHERWISE SPECIFIED:
 DIMENSIONS ARE IN MILLIMETERS
 SURFACE FINISH:
 TOLERANCES:
 LINEAR:
 ANGULAR:

FINISH:

DEBUR AND
 BREAK SHARP
 EDGES

DO NOT SCALE DRAWING

REVISION

	NAME	SIGNATURE	DATE		
DRAWN					
CHK'D					
APPV'D					
MFG					
Q.A					
				MATERIAL:	
				1.0037 (S235JR)	
				WEIGHT: 0.12	

TITLE:

DWG NO.

BSPN-0412-11

A4

SCALE:1:1

SHEET 1 OF 1

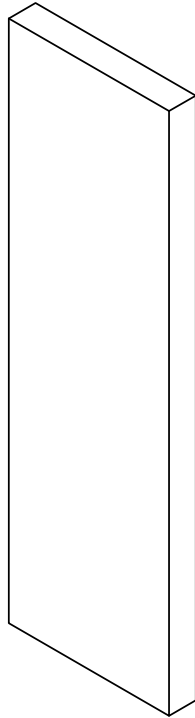
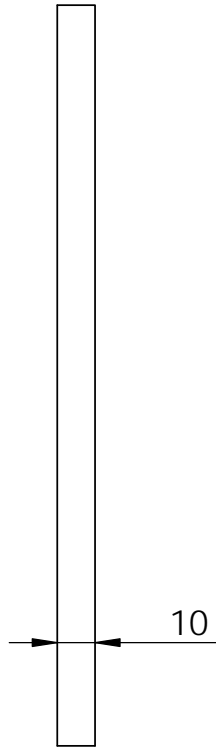
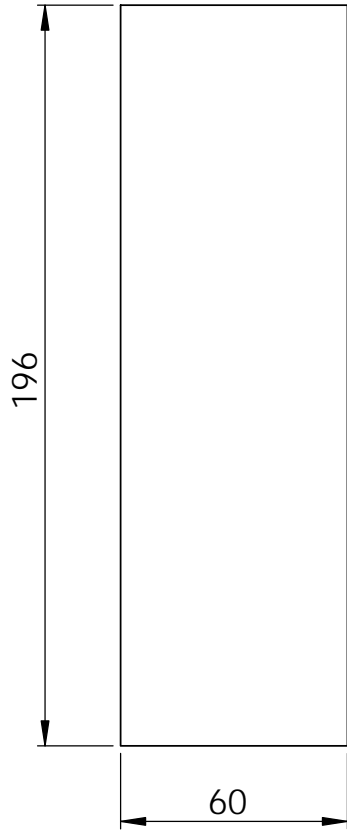

UNLESS OTHERWISE SPECIFIED:
 DIMENSIONS ARE IN MILLIMETERS
 SURFACE FINISH:
 TOLERANCES:
 LINEAR:
 ANGULAR:

FINISH:

DEBUR AND
 BREAK SHARP
 EDGES

DO NOT SCALE DRAWING

REVISION

	NAME	SIGNATURE	DATE		
DRAWN					
CHK'D					
APPV'D					
MFG					
Q.A					
				MATERIAL:	
				1.0037 (S235JR)	
				WEIGHT: 0.92	

TITLE:

DWG NO.

BSPN-0412-12

A4

SCALE:1:2

SHEET 1 OF 1

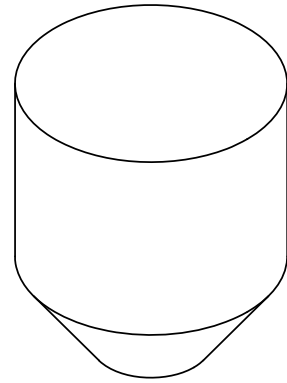
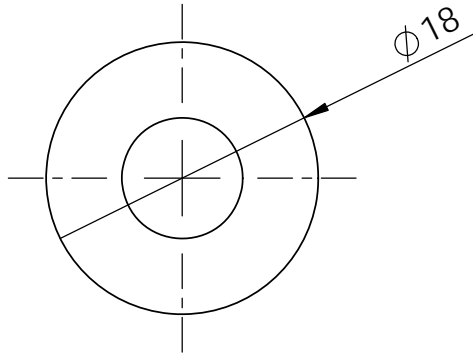
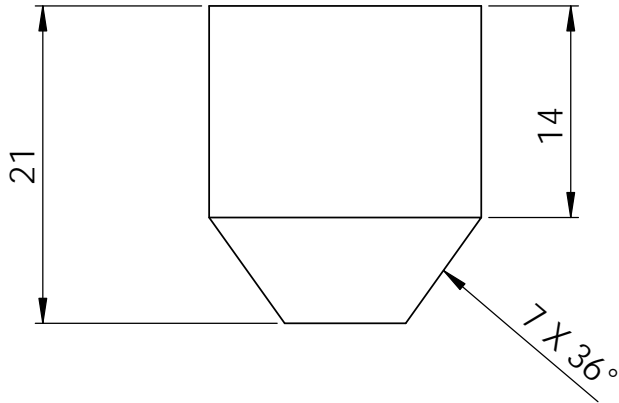

UNLESS OTHERWISE SPECIFIED:
DIMENSIONS ARE IN MILLIMETERS
SURFACE FINISH:
TOLERANCES:
LINEAR:
ANGULAR:

FINISH:

DEBUR AND
BREAK SHARP
EDGES

DO NOT SCALE DRAWING

REVISION

	NAME	SIGNATURE	DATE		
DRAWN					
CHK'D					
APPV'D					
MFG					
Q.A					
				MATERIAL:	
				1.0037 (S235JR)	
				WEIGHT: 0.04	

TITLE:

DWG NO.

BSPN-0412-13

A4

SCALE:2:1

SHEET 1 OF 1

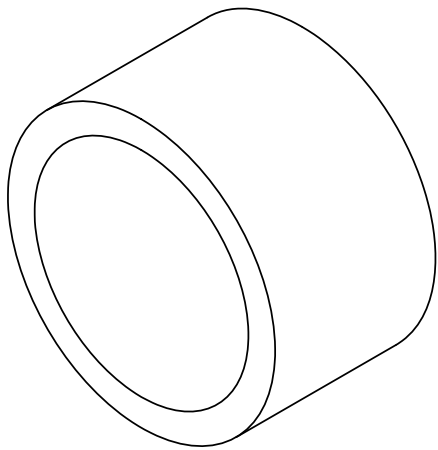
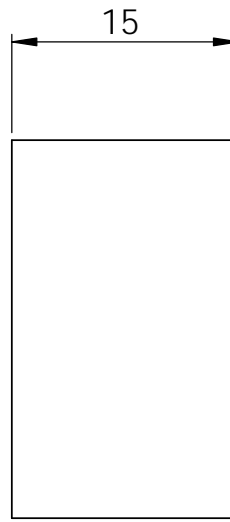
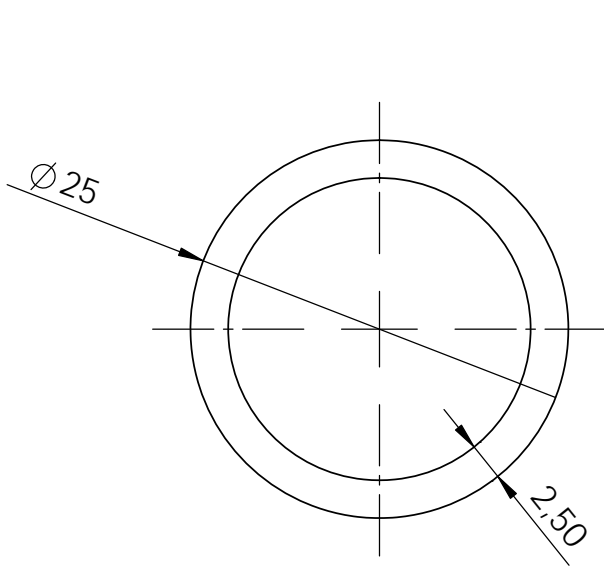

UNLESS OTHERWISE SPECIFIED: DIMENSIONS ARE IN MILLIMETERS SURFACE FINISH: TOLERANCES: LINEAR: ANGULAR:		FINISH:		DEBUR AND BREAK SHARP EDGES		DO NOT SCALE DRAWING		REVISION	
DRAWN		SIGNATURE		DATE		TITLE:			
CHK'D									
APPV'D									
MFG									
O.A				MATERIAL:		DWG NO.		BSPN-0412-14	
				1.0037 (S235JR)				A4	
				WEIGHT: 0.02		SCALE: 2:1		SHEET 1 OF 1	

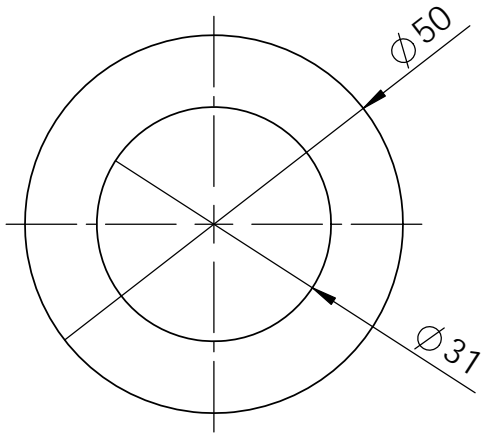
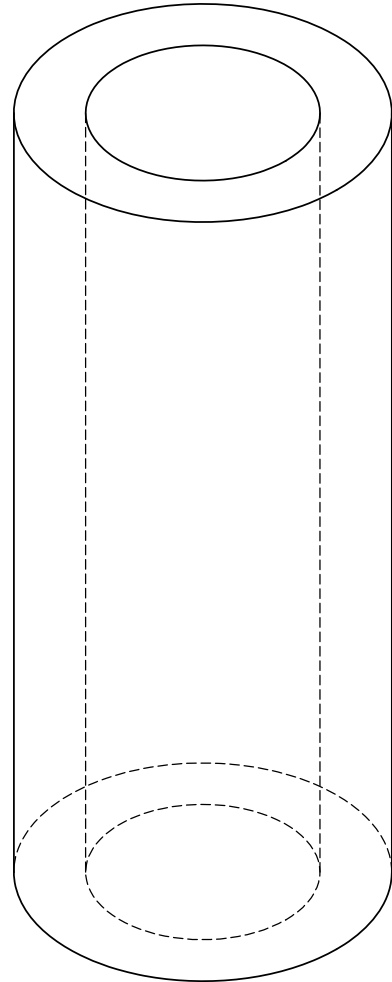
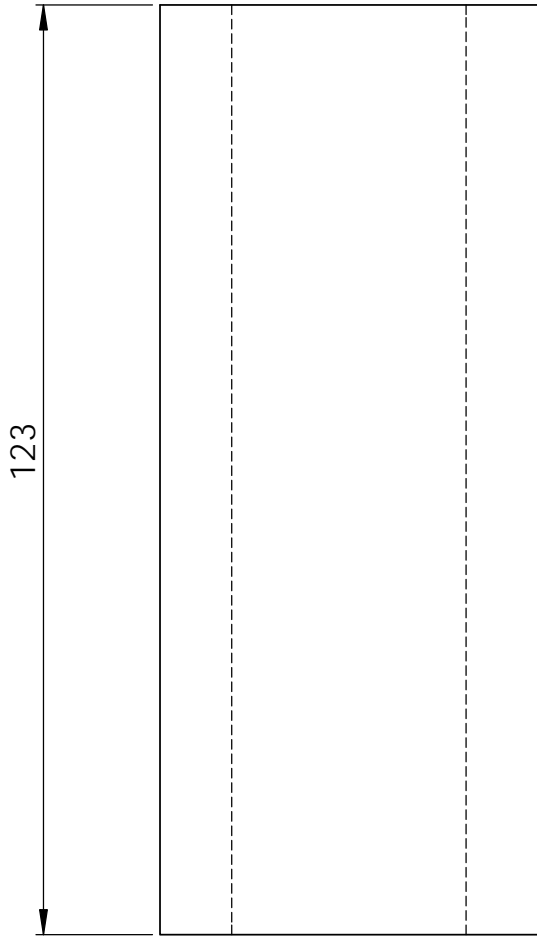

UNLESS OTHERWISE SPECIFIED:
 DIMENSIONS ARE IN MILLIMETERS
 SURFACE FINISH:
 TOLERANCES:
 LINEAR:
 ANGULAR:

FINISH:

DEBUR AND
 BREAK SHARP
 EDGES

DO NOT SCALE DRAWING

REVISION

	NAME	SIGNATURE	DATE		
DRAWN					
CHK'D					
APPV'D					
MFG					
Q.A					
				MATERIAL:	
				1.0037 (S235JR)	
				WEIGHT: 1.16	

TITLE:

DWG NO.

BSPN-0412-17

A4

SCALE:1:2

SHEET 1 OF 1

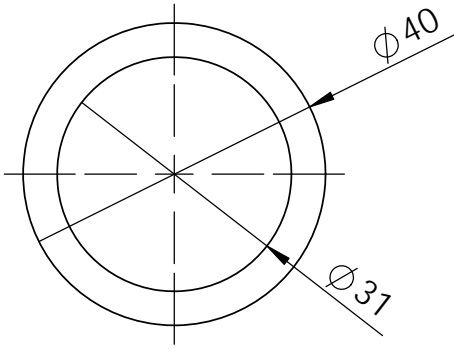
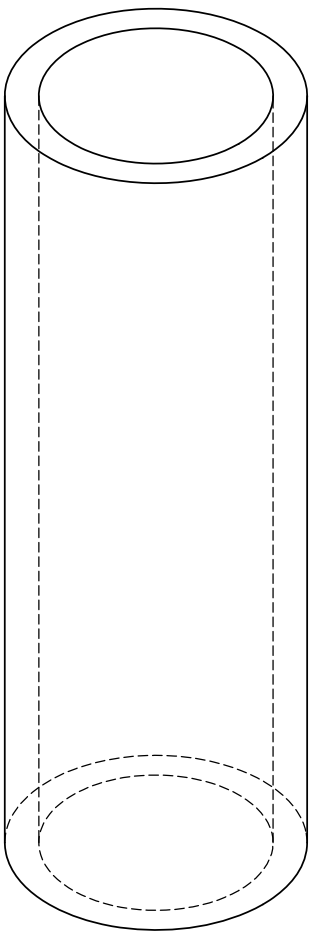
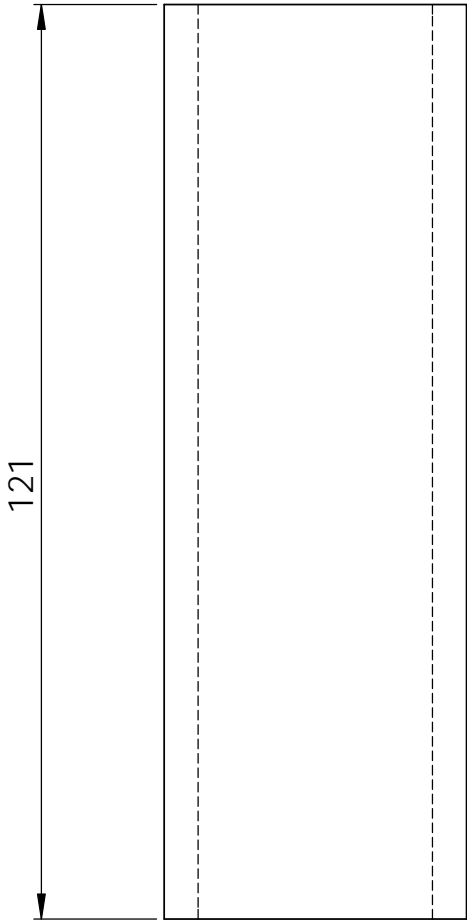

UNLESS OTHERWISE SPECIFIED:
 DIMENSIONS ARE IN MILLIMETERS
 SURFACE FINISH:
 TOLERANCES:
 LINEAR:
 ANGULAR:

FINISH:

DEBUR AND
 BREAK SHARP
 EDGES

DO NOT SCALE DRAWING

REVISION

	NAME	SIGNATURE	DATE		
DRAWN					
CHK'D					
APPV'D					
MFG					
Q.A					
				MATERIAL:	
				1.0037 (S235JR)	
				WEIGHT: 0.47	

TITLE:	
DWG NO.	BSPN-0412-18
SCALE:1:2	SHEET 1 OF 1
	A4

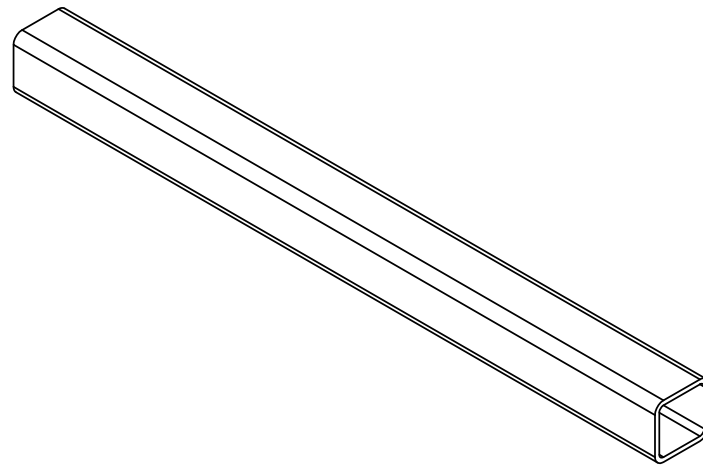
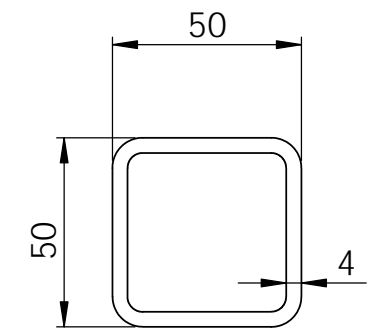
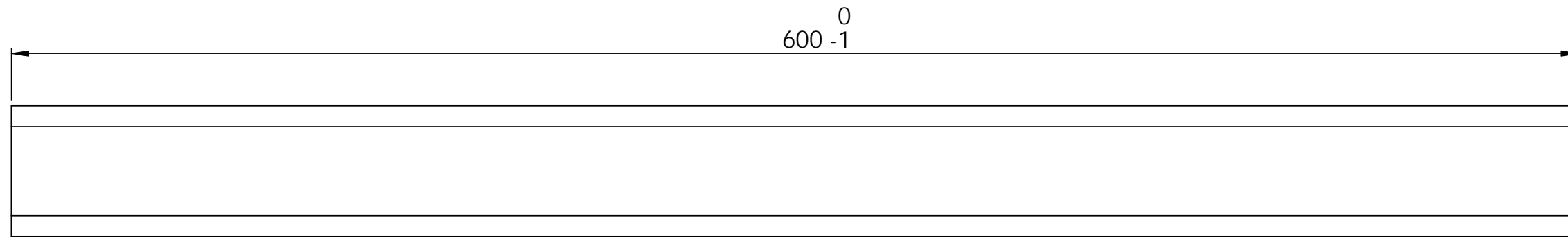

UNLESS OTHERWISE SPECIFIED: DIMENSIONS ARE IN MILLIMETERS SURFACE FINISH: TOLERANCES: LINEAR: ANGULAR:				FINISH:		DEBUR AND BREAK SHARP EDGES		DO NOT SCALE DRAWING		REVISION	
DRAWN				NAME		SIGNATURE		DATE		TITLE:	
CHK'D											
APPV'D											
MFG											
Q.A								MATERIAL:		DWG NO.	
								1.0037 (S235JR)		BSPN-0412-19	
								WEIGHT: 3.25		SCALE:1:5	
										SHEET 1 OF 1	
										A3	

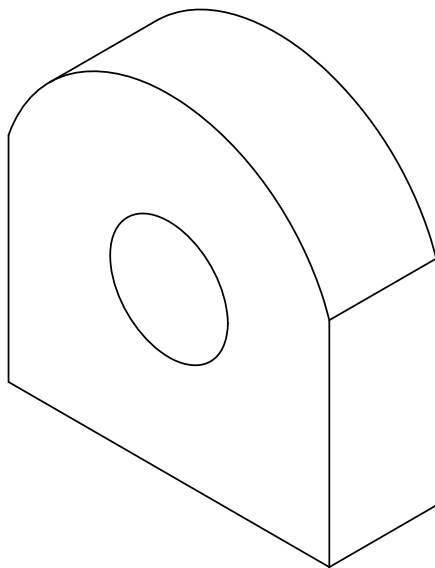
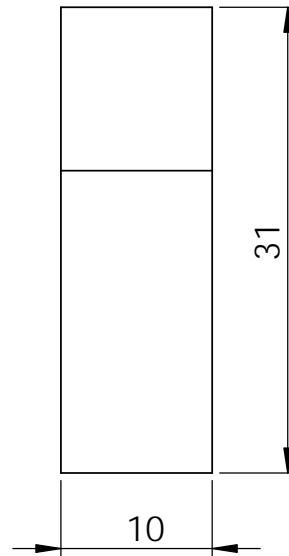
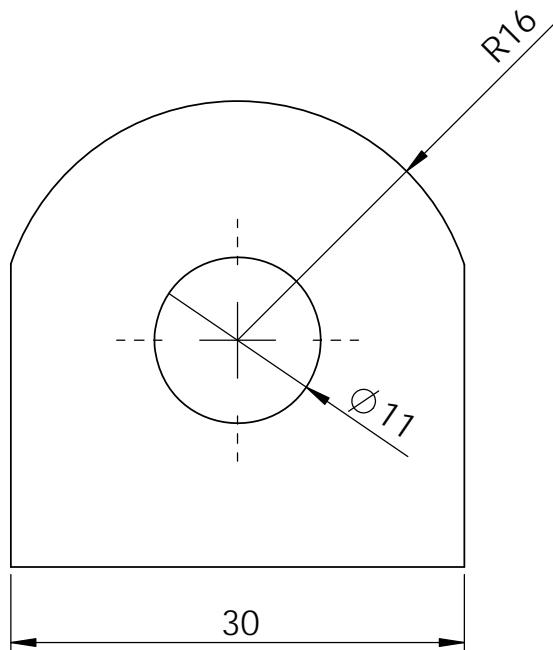

UNLESS OTHERWISE SPECIFIED: DIMENSIONS ARE IN MILLIMETERS SURFACE FINISH: TOLERANCES: LINEAR: ANGULAR:				FINISH:		DEBUR AND BREAK SHARP EDGES		DO NOT SCALE DRAWING		REVISION	
								TITLE:			
DRAWN		SIGNATURE		DATE							
CHK'D											
APPV'D											
MFG											
O.A.				MATERIAL: 1.0037 (S235JR)				DWG NO.		BSPN-0412-20	
				WEIGHT: 0.06				SCALE: 2:1		SHEET 1 OF 1	
										A4	

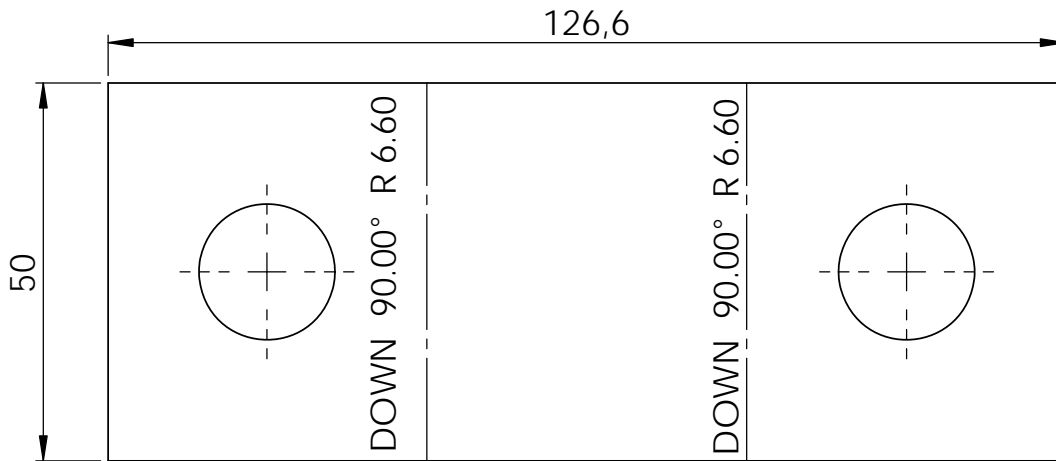
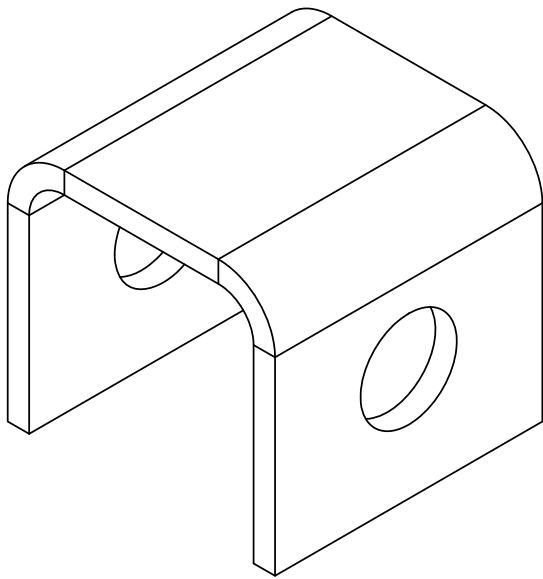
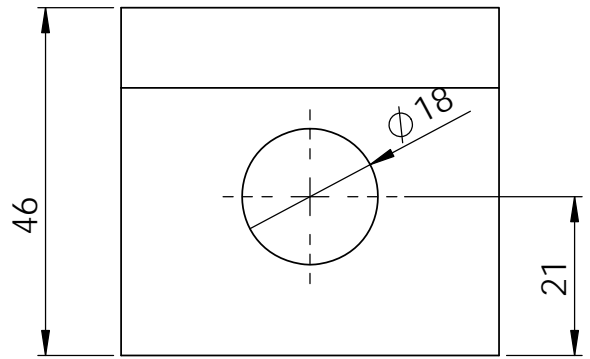
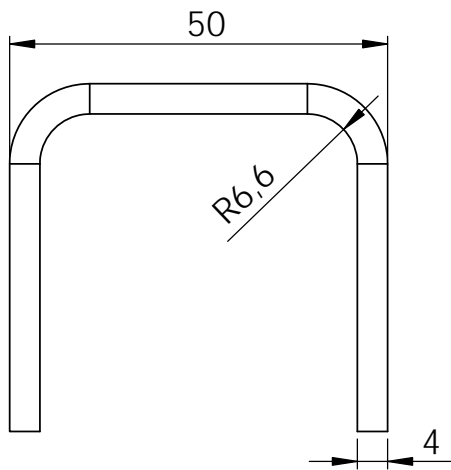

UNLESS OTHERWISE SPECIFIED:
 DIMENSIONS ARE IN MILLIMETERS
 SURFACE FINISH:
 TOLERANCES:
 LINEAR:
 ANGULAR:

FINISH:

DEBUR AND
 BREAK SHARP
 EDGES

DO NOT SCALE DRAWING

REVISION

	NAME	SIGNATURE	DATE		
DRAWN					
CHK'D					
APPV'D					
MFG					
Q.A					
				MATERIAL:	
				1.0037 (S235JR)	
				WEIGHT: 0.18	

TITLE:	
DWG NO.	BSPN-0412-21
SCALE:1:1	SHEET 1 OF 1
	A4

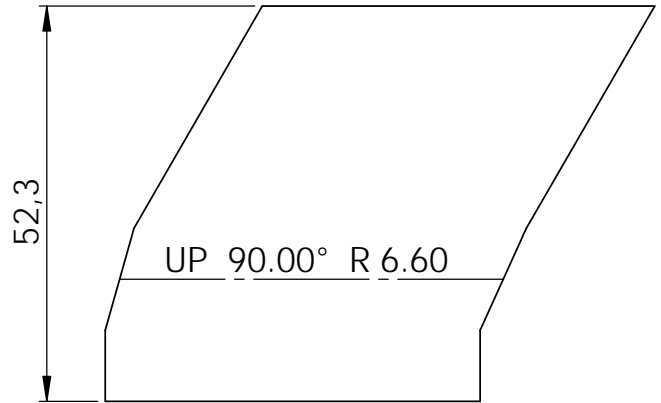
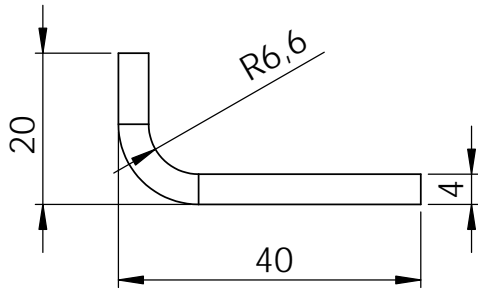

NOTE:
For Part, number BSPN-0412-23
Bend 90 degrees down

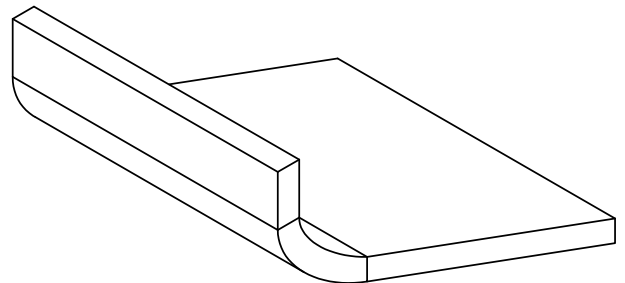
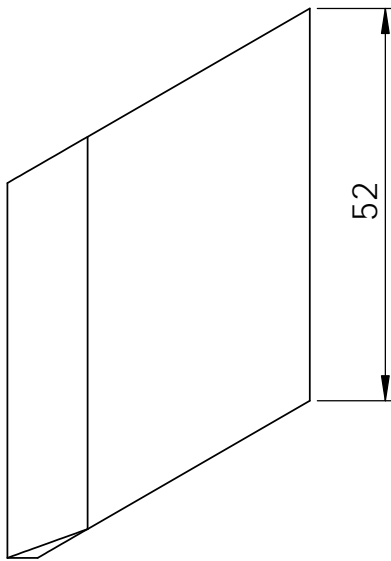

UNLESS OTHERWISE SPECIFIED:
DIMENSIONS ARE IN MILLIMETERS
SURFACE FINISH:
TOLERANCES:
LINEAR:
ANGULAR:

FINISH:

DEBUR AND
BREAK SHARP
EDGES

DO NOT SCALE DRAWING

REVISION

	NAME	SIGNATURE	DATE		
DRAWN					
CHK'D					
APPV'D					
MFG					
Q.A					
				MATERIAL:	
				1.0037 (S235JR)	
				WEIGHT: 0.08	

TITLE:

DWG NO.

BSPN-0412-22/23

A4

SCALE:1:1

SHEET 1 OF 1

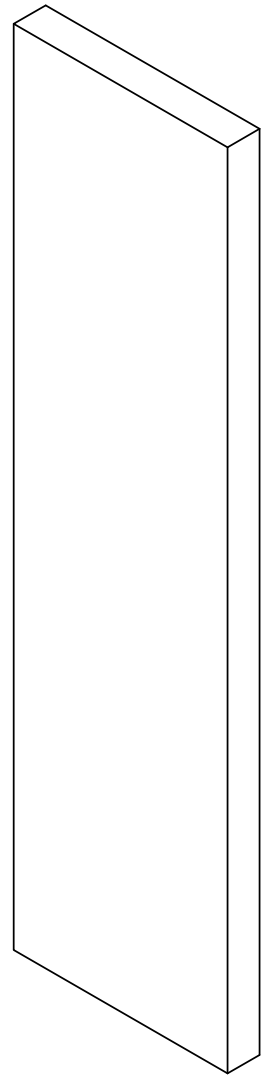
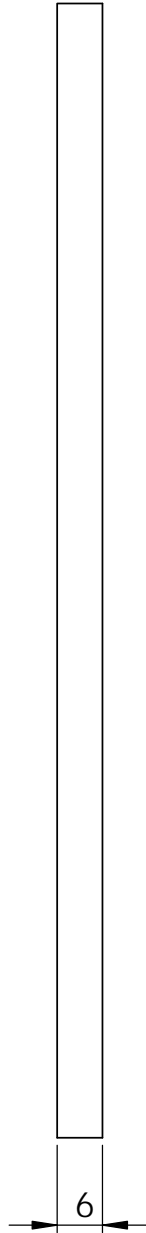
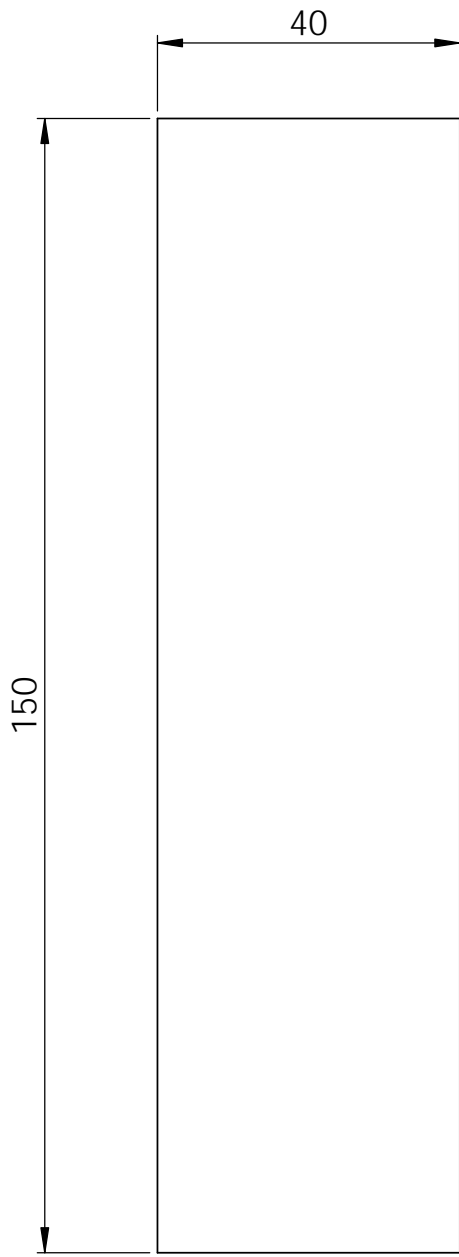

UNLESS OTHERWISE SPECIFIED:
 DIMENSIONS ARE IN MILLIMETERS
 SURFACE FINISH:
 TOLERANCES:
 LINEAR:
 ANGULAR:

FINISH:

DEBUR AND
 BREAK SHARP
 EDGES

DO NOT SCALE DRAWING

REVISION

	NAME	SIGNATURE	DATE		
DRAWN					
CHK'D					
APPV'D					
MFG					
Q.A					
				MATERIAL:	
					1.0037 (S235JR)
				WEIGHT: 0.28	

TITLE:

DWG NO.

BSPN-0412-31

A4

SCALE:1:2

SHEET 1 OF 1

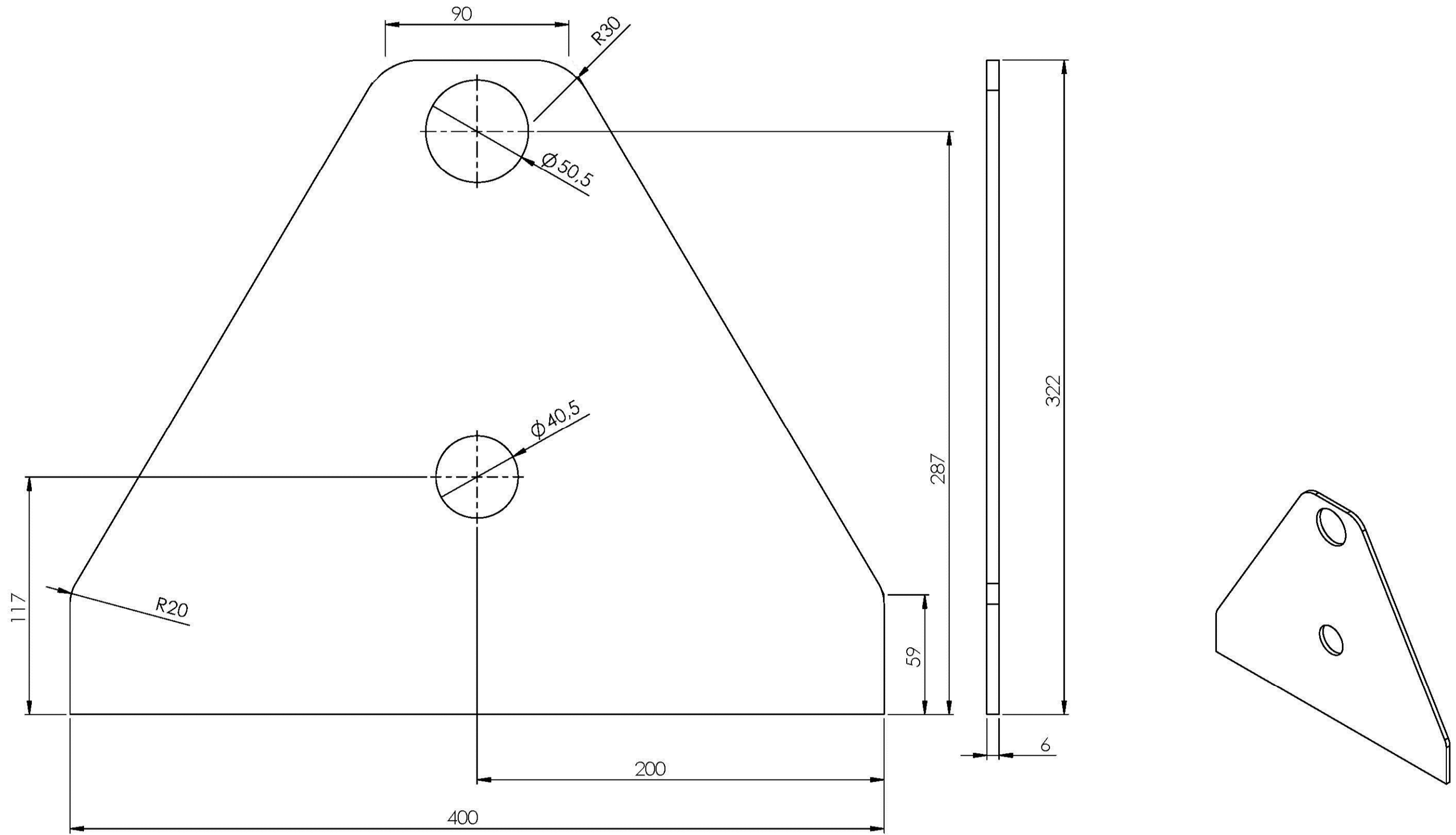

UNLESS OTHERWISE SPECIFIED: DIMENSIONS ARE IN MILLIMETERS SURFACE FINISH: TOLERANCES: LINEAR: ANGULAR:				FINISH:		DEBUR AND BREAK SHARP EDGES		DO NOT SCALE DRAWING		REVISION	
DRAWN				SIGNATURE		DATE		TITLE:		DWG NO: BSPN-0412V2-15	
CHK'D				SIGNATURE		DATE		TITLE:		A3	
APPV'D				SIGNATURE		DATE		TITLE:		SCALE: 1:2	
MFG:				SIGNATURE		DATE		TITLE:		SHEET 1 OF 1	
Q.A:				SIGNATURE		DATE		TITLE:		MATERIAL: 1.0037 (S235JR)	
				SIGNATURE		DATE		TITLE:		WEIGHT: 3.97	

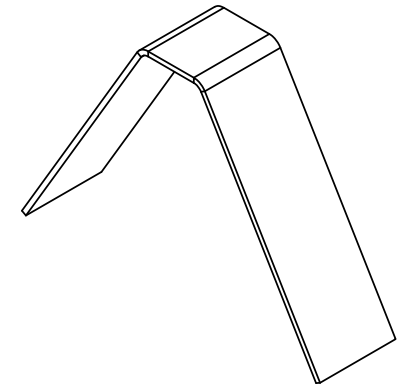
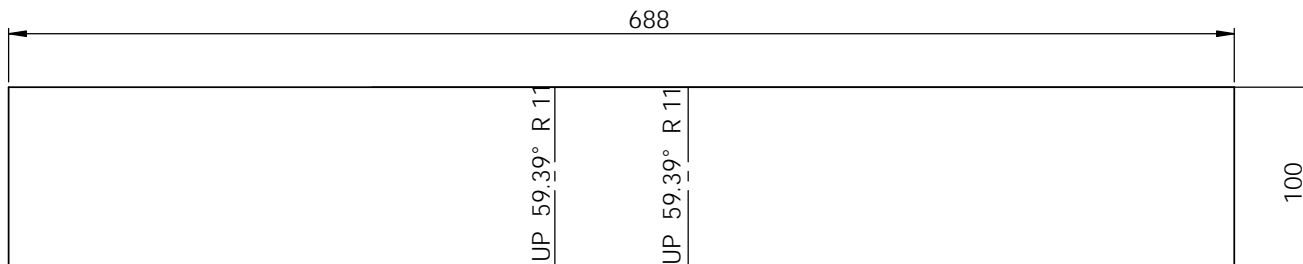
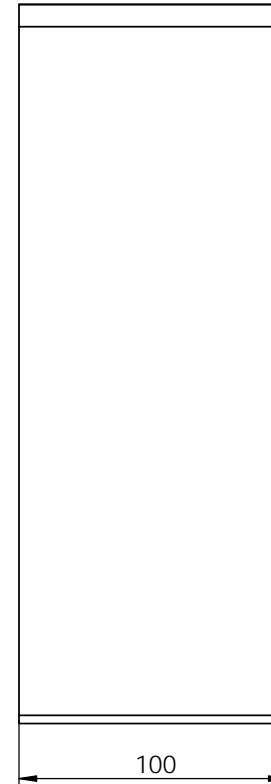
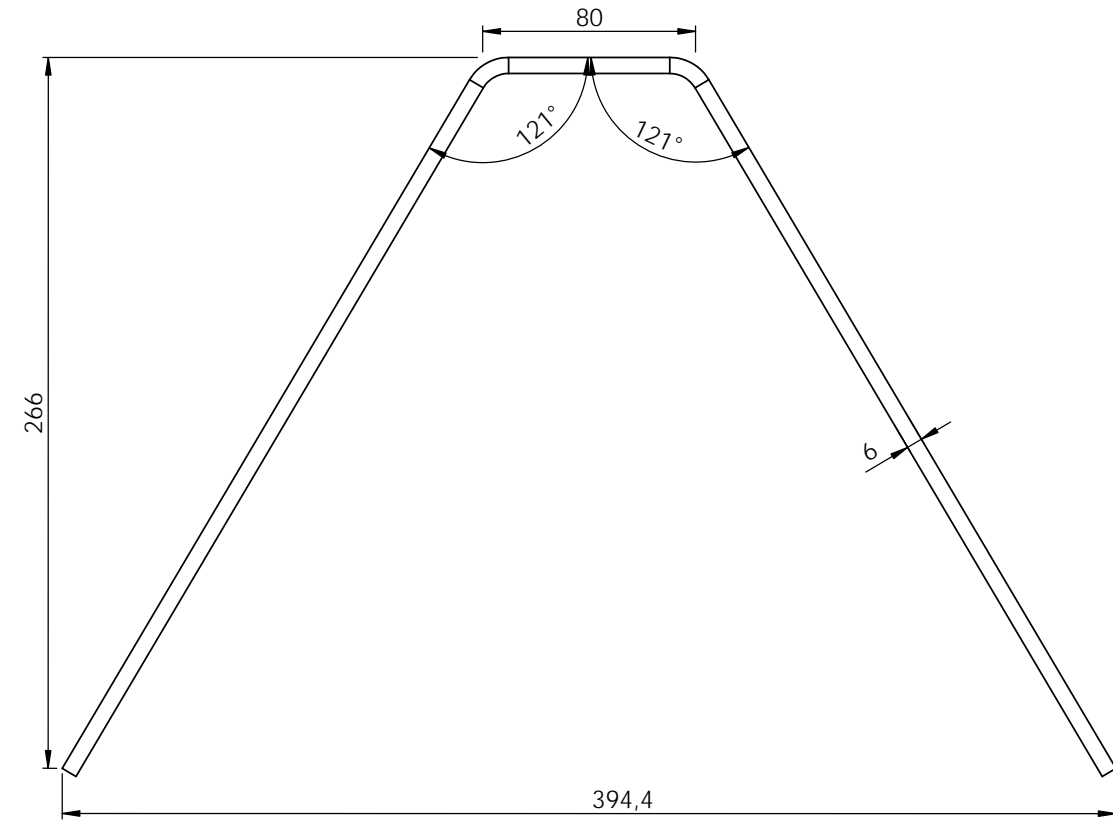

UNLESS OTHERWISE SPECIFIED: DIMENSIONS ARE IN MILLIMETERS				FINISH:		DEBUR AND BREAK SHARP EDGES		DO NOT SCALE DRAWING		REVISION	
SURFACE FINISH:											
TOLERANCES:											
LINEAR:											
ANGULAR:											
DRAWN		NAME		SIGNATURE		DATE		TITLE:			
CHKD											
APPVD											
MFG											
Q.A								MATERIAL:		DWG NO.	
								1.0037 (S235JR)		BSPN-0412V2-16	
								WEIGHT: 3.22		SCALE: 1:5	
										SHEET 1 OF 1	
										A3	

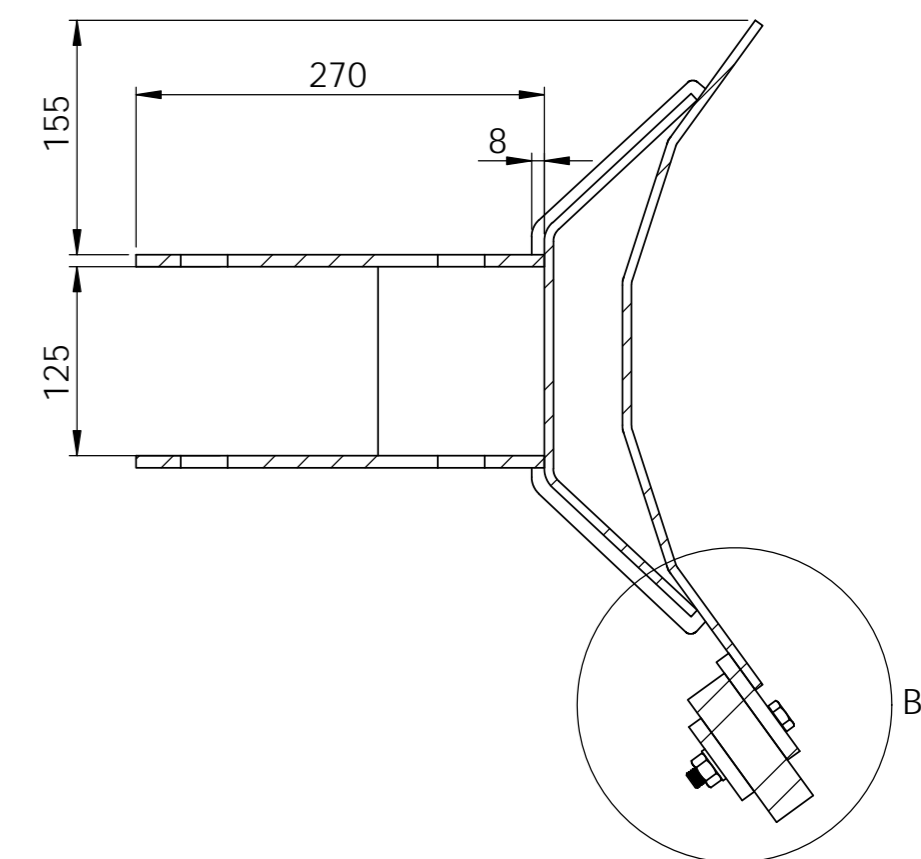
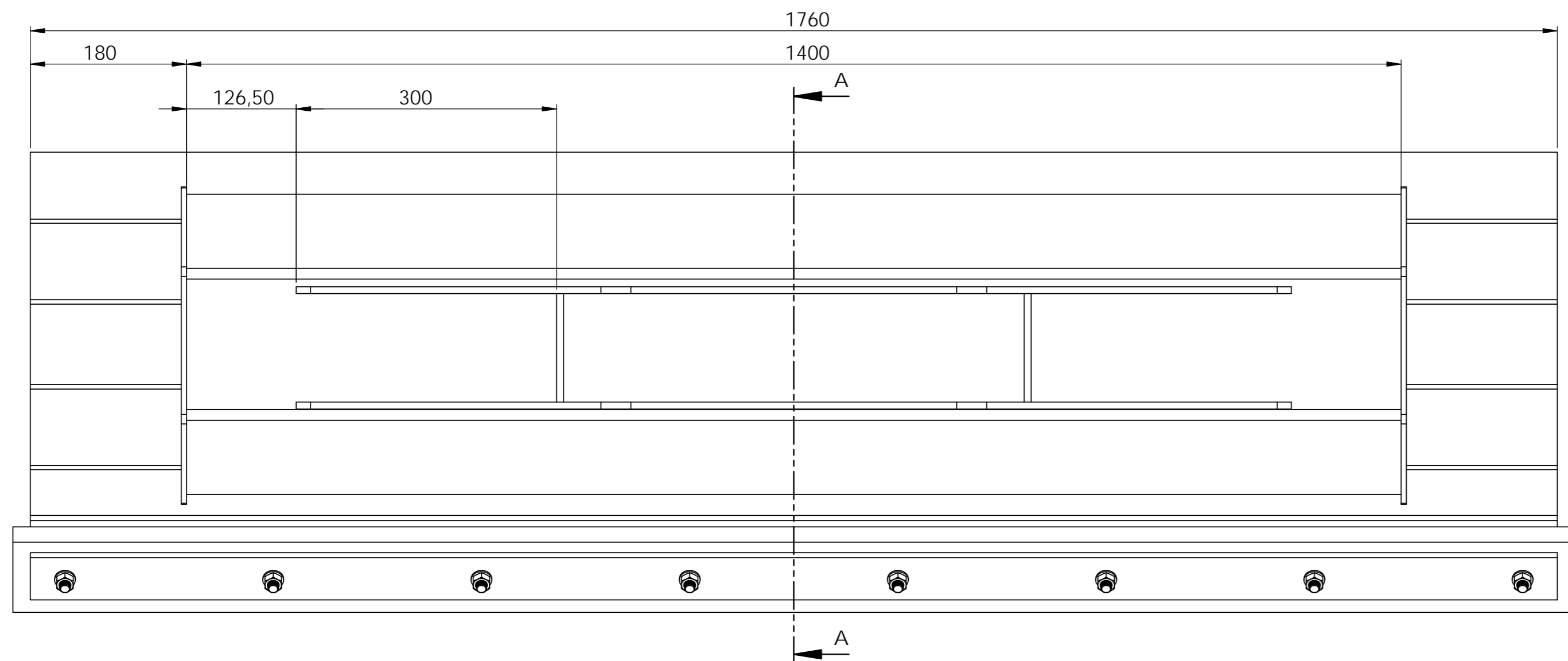

SECTION A-A
SCALE 1 : 5

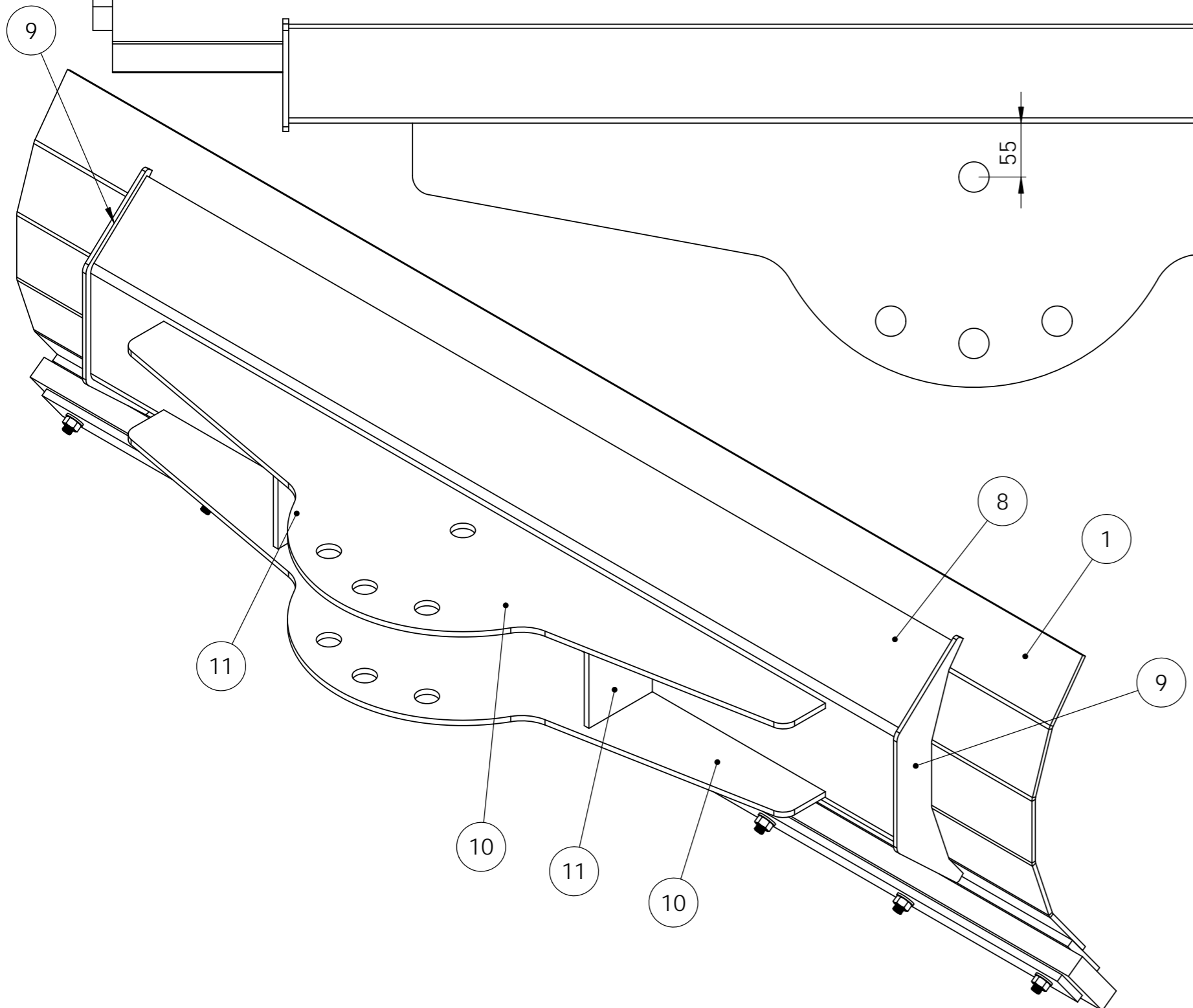
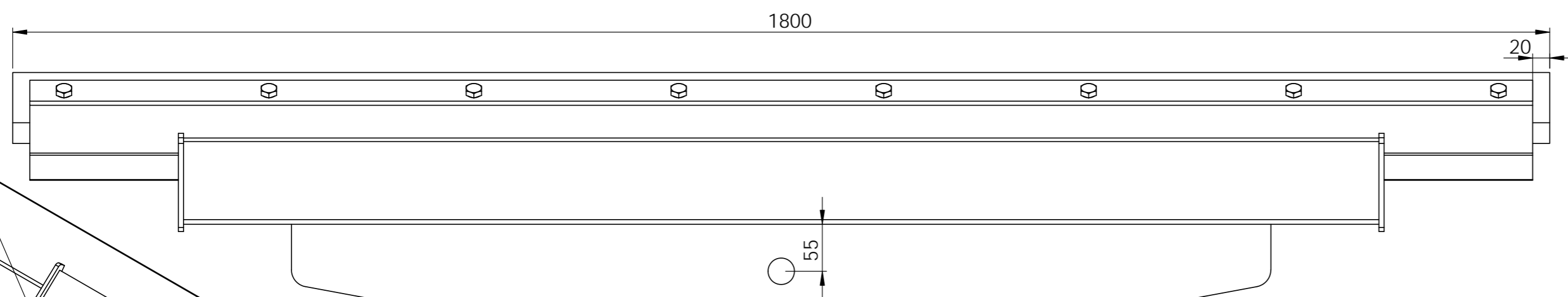

DETAIL B
SCALE 1 : 2

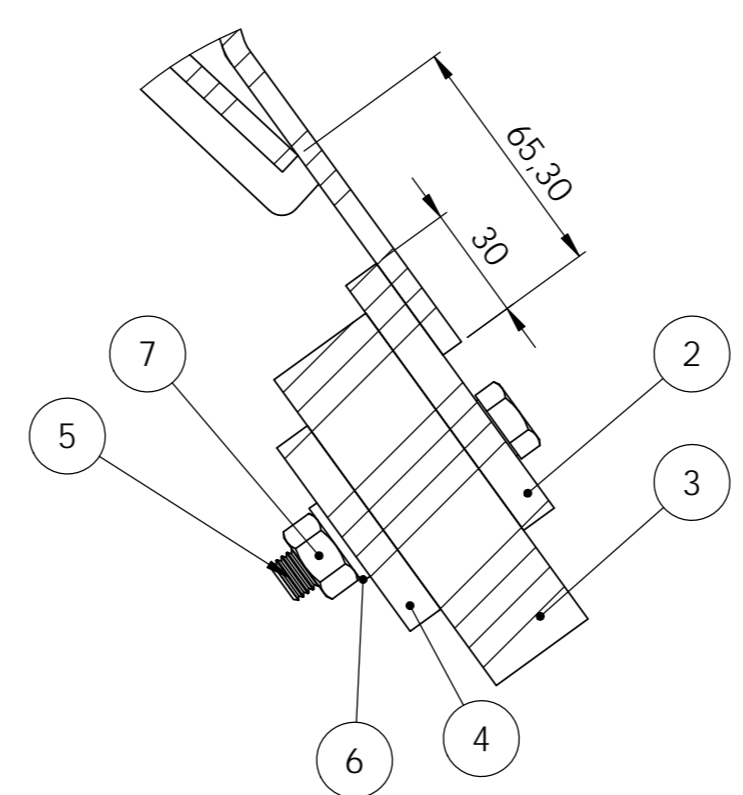

ITEM NO.	PART NUMBER	DESCRIPTION	QTY.
1	BSPN-0412-01		1
2	BSPN-0412-02		1
3	BSPN-0412-03		1
4	BSPN-0412-04		1
5	ISO 4014 - M12 x 70 x 30		8
6	washer-12		8
7	M12-standard nut		8
8	BSPN-0412-05		1
9	BSPN-0412-06		2
10	BSPN-0412V2-07		2
11	BSPN-0412-08		2

UNLESS OTHERWISE SPECIFIED: DIMENSIONS ARE IN MILLIMETERS		FINISH: RAL 3000 Powder coated	DEBUR AND BREAK SHARP EDGES	DO NOT SCALE DRAWING	REVISION
SURFACE FINISH:					
TOLERANCES:					
LINEAR:					
ANGULAR:					
DRAWN	NAME	SIGNATURE	DATE	TITLE:	
CHK'D					
APP'VD					
MFG					
Q.A				MATERIAL:	DWG NO. BSPN-0412V2-A1 A2
				Material <not specified>	
				WEIGHT: 117.43	SCALE:1:20 SHEET 1 OF 2

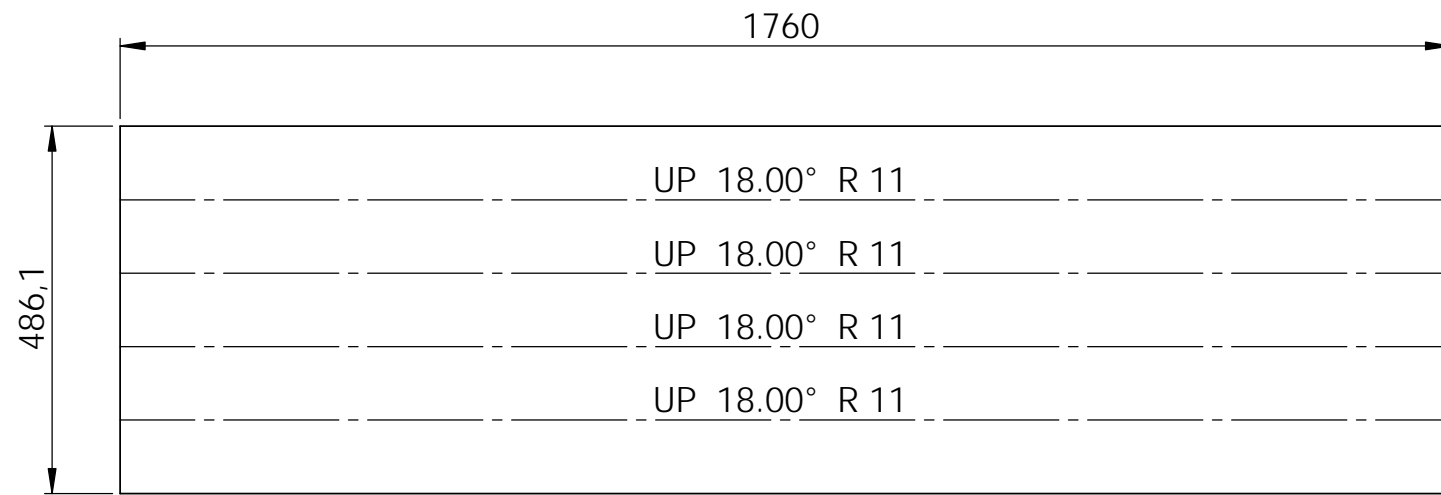
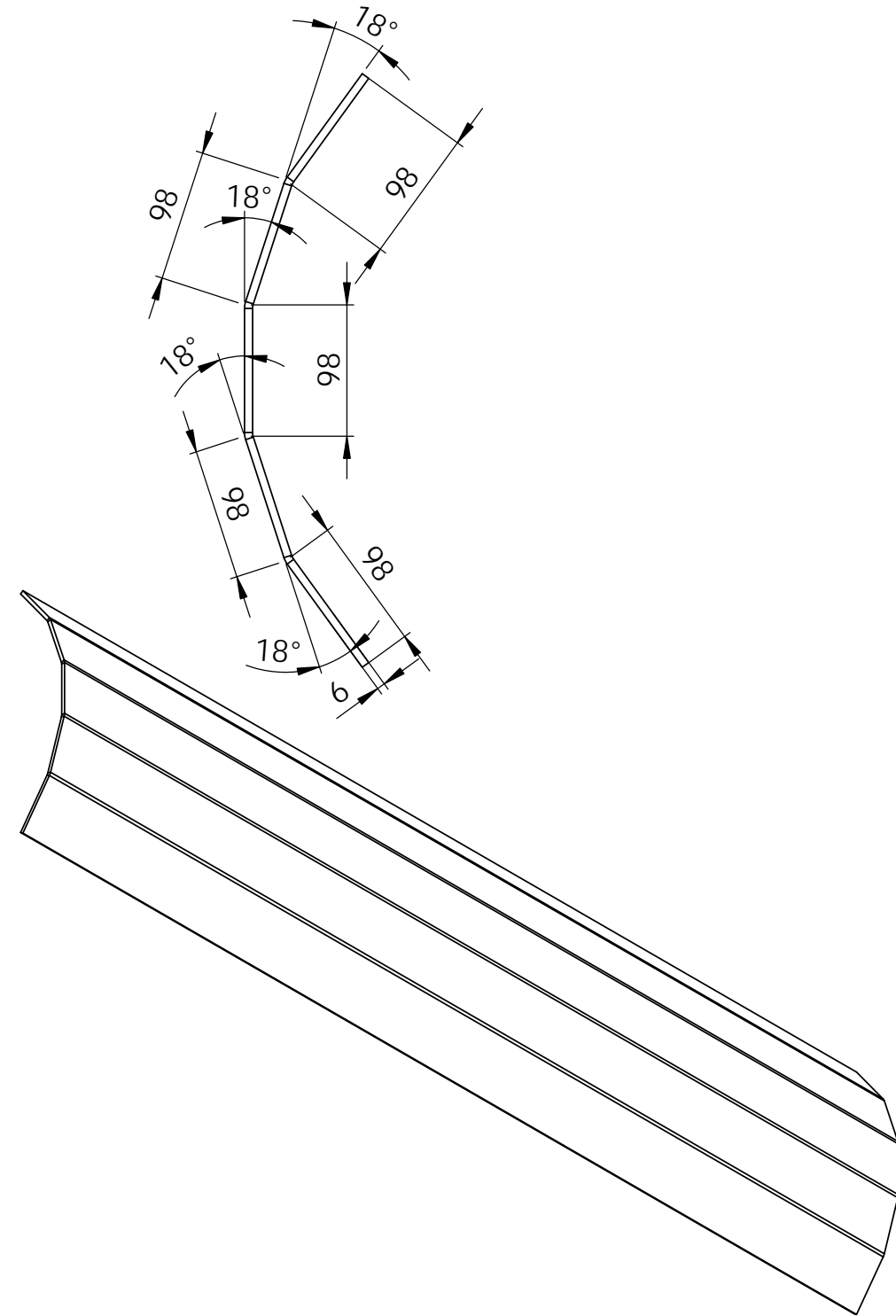
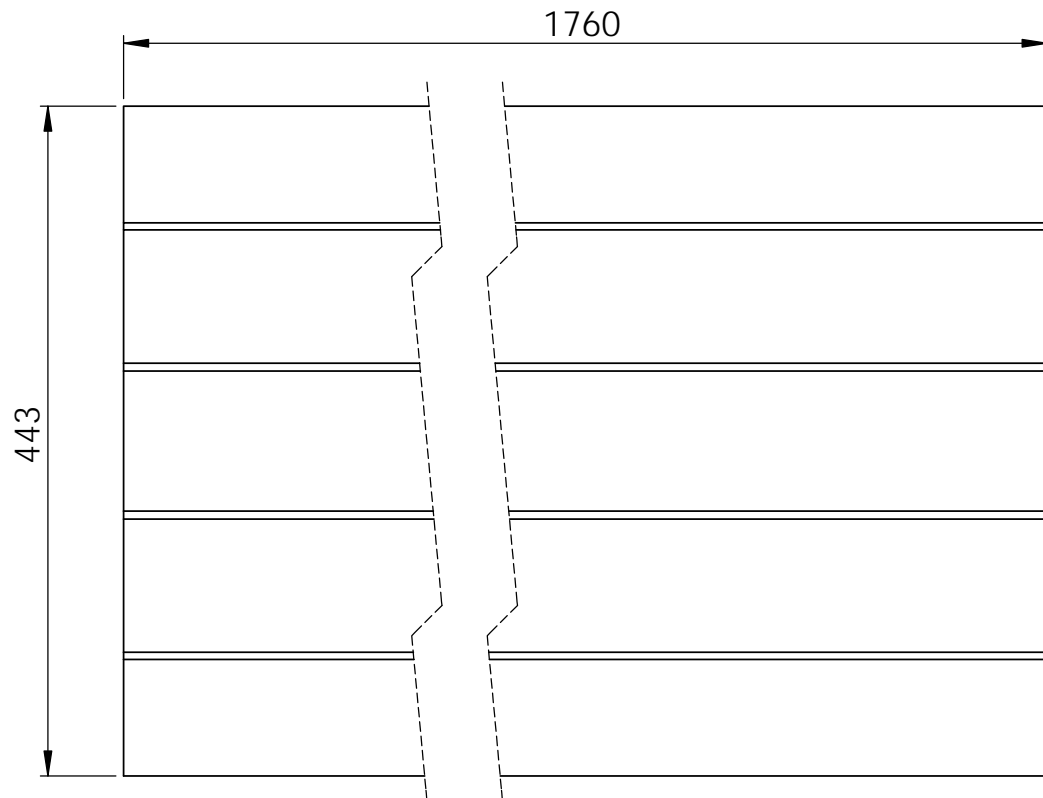

UNLESS OTHERWISE SPECIFIED: DIMENSIONS ARE IN MILLIMETERS SURFACE FINISH: TOLERANCES: LINEAR: ANGULAR:				FINISH:		DEBUR AND BREAK SHARP EDGES		DO NOT SCALE DRAWING		REVISION	
DRAWN				SIGNATURE		DATE		TITLE:			
CHK'D				SIGNATURE		DATE		TITLE:			
APPV'D				SIGNATURE		DATE		TITLE:			
MFG				SIGNATURE		DATE		TITLE:			
Q.A				SIGNATURE		DATE		MATERIAL: 1.0037 (S235JR)		DWG NO. BSPN-0412-01	
				SIGNATURE		DATE		WEIGHT: 40.04		SCALE:1:20	
				SIGNATURE		DATE				SHEET 1 OF 1	
				SIGNATURE		DATE				A3	

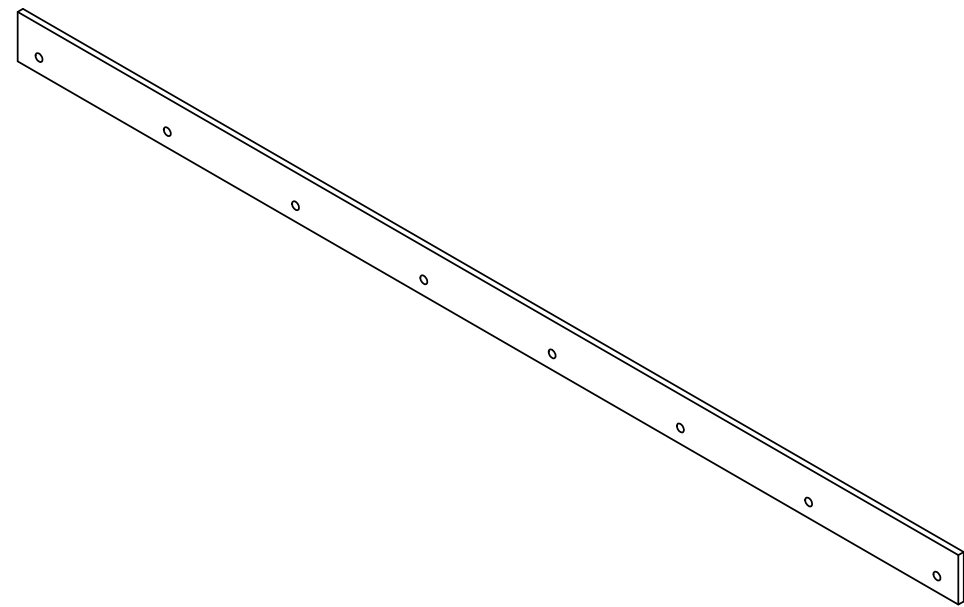
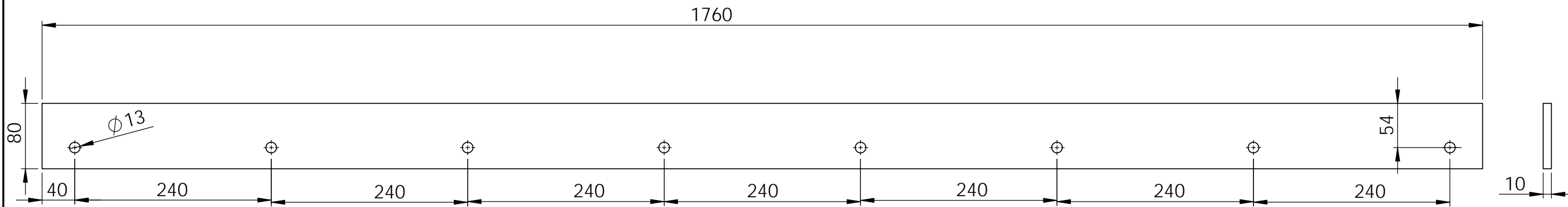

UNLESS OTHERWISE SPECIFIED: DIMENSIONS ARE IN MILLIMETERS SURFACE FINISH: TOLERANCES: LINEAR: ANGULAR:				FINISH:		DEBUR AND BREAK SHARP EDGES		DO NOT SCALE DRAWING		REVISION	
								TITLE:			
DRAWN				NAME		SIGNATURE		DATE			
CHK'D											
APPV'D											
MFG											
Q.A								MATERIAL:		DWG NO.	
								1.0037 (S235JR)		BSPN-0412-02	
								WEIGHT: 10.90		SCALE: 1:10	
										SHEET 1 OF 1	
										A3	

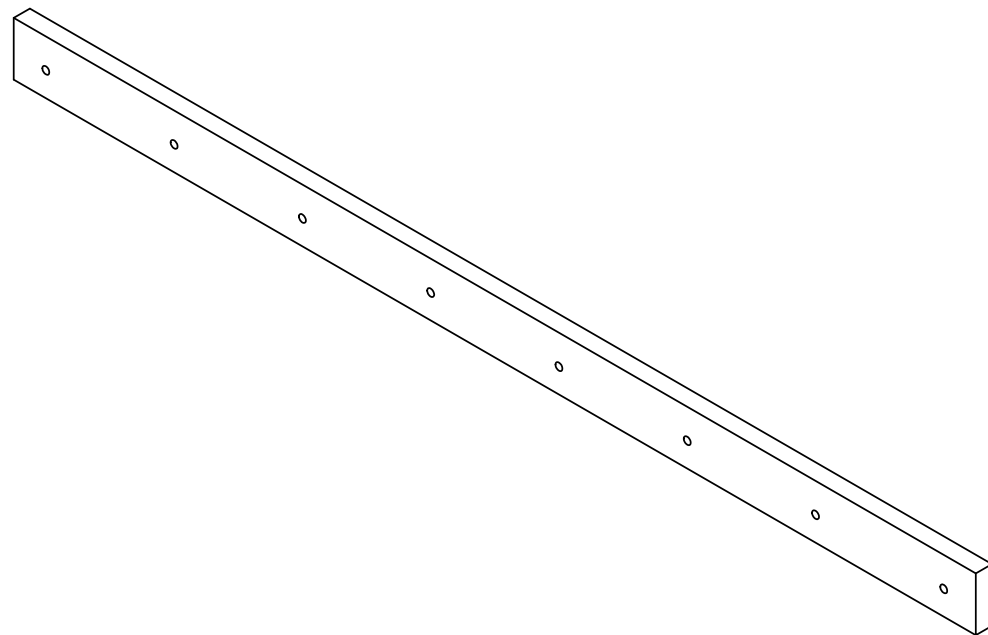
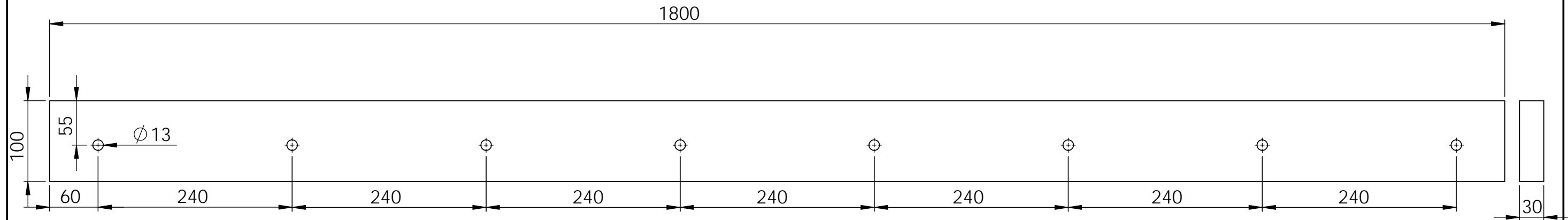

UNLESS OTHERWISE SPECIFIED: DIMENSIONS ARE IN MILLIMETERS				FINISH:		DEBUR AND BREAK SHARP EDGES		DO NOT SCALE DRAWING		REVISION	
SURFACE FINISH:											
TOLERANCES:											
LINEAR:											
ANGULAR:											
	NAME	SIGNATURE	DATE					TITLE:			
DRAWN											
CHK'D											
APPV'D											
MFG											
Q.A				MATERIAL:			Rubber		DWG NO.		BSPN-0412-03
				5 textile layers EP160					A3		
				65 Sha							
				WEIGHT: 5.37					SCALE:1:10		SHEET 1 OF 1

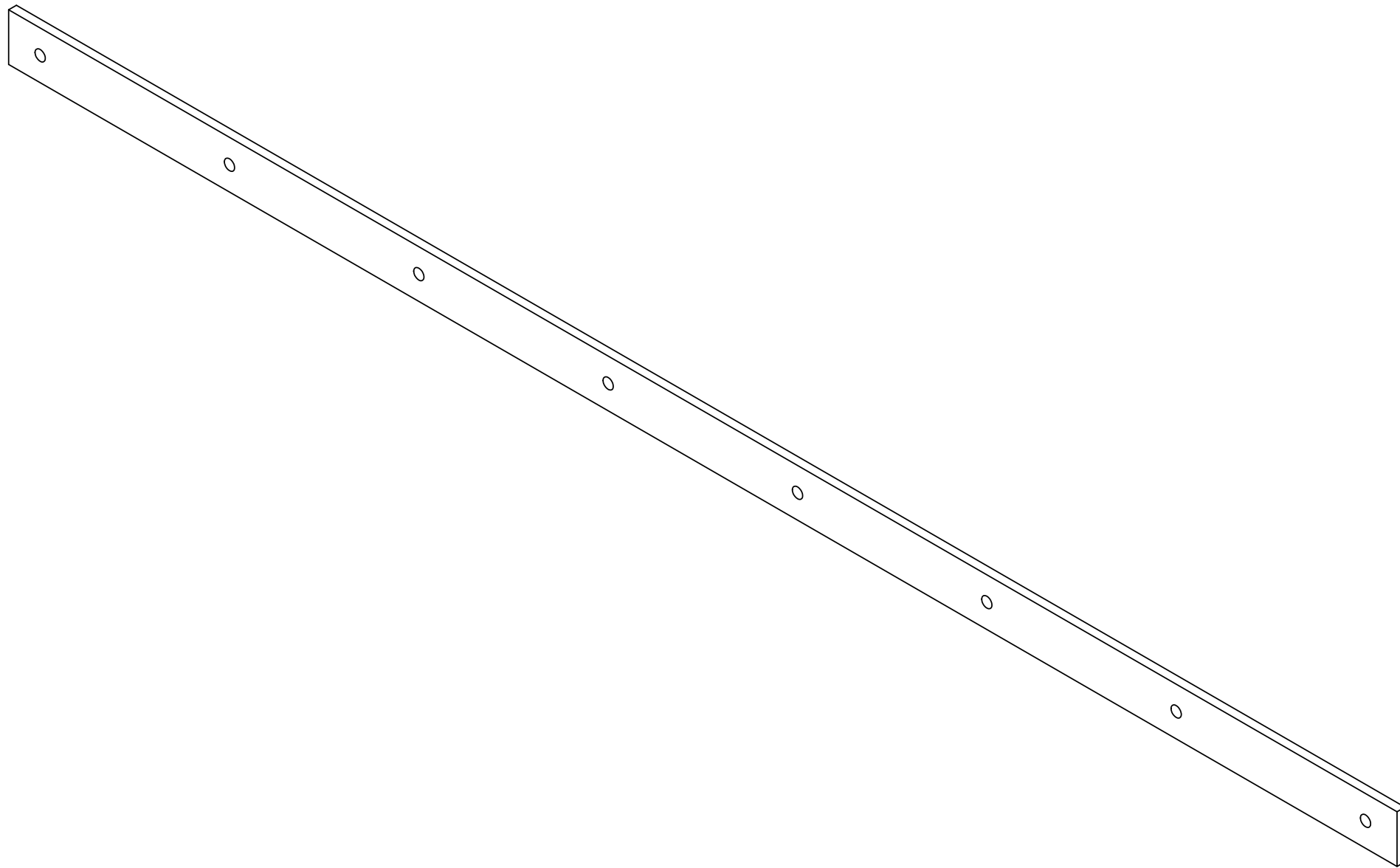
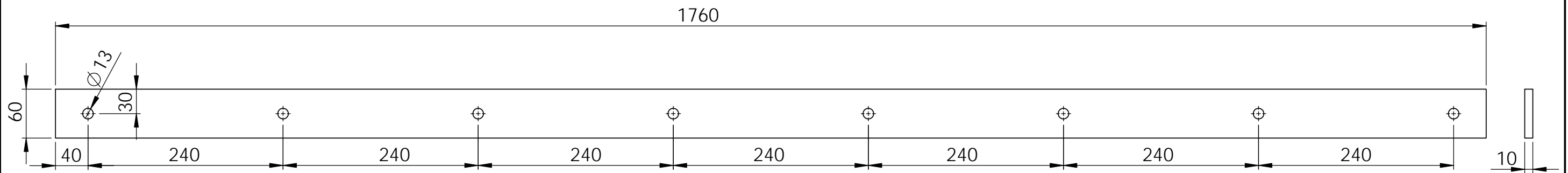

UNLESS OTHERWISE SPECIFIED: DIMENSIONS ARE IN MILLIMETERS SURFACE FINISH: TOLERANCES: LINEAR: ANGULAR:				FINISH:		DEBUR AND BREAK SHARP EDGES		DO NOT SCALE DRAWING		REVISION	
DRAWN				SIGNATURE		DATE		TITLE:			
CHK'D				SIGNATURE		DATE		TITLE:			
APPV'D				SIGNATURE		DATE		TITLE:			
MFG				SIGNATURE		DATE		TITLE:			
Q.A				SIGNATURE		DATE		TITLE:			
				MATERIAL:		1.0037 (S235JR)		DWG NO.		BSPN-0412-04	
				WEIGHT: 8.15				SCALE: 1:10		SHEET 1 OF 1	
										A3	

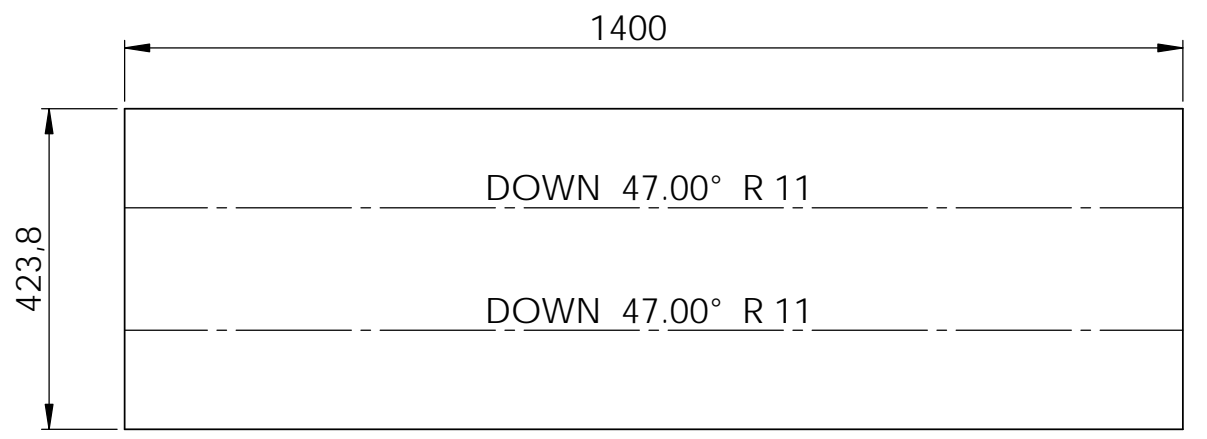
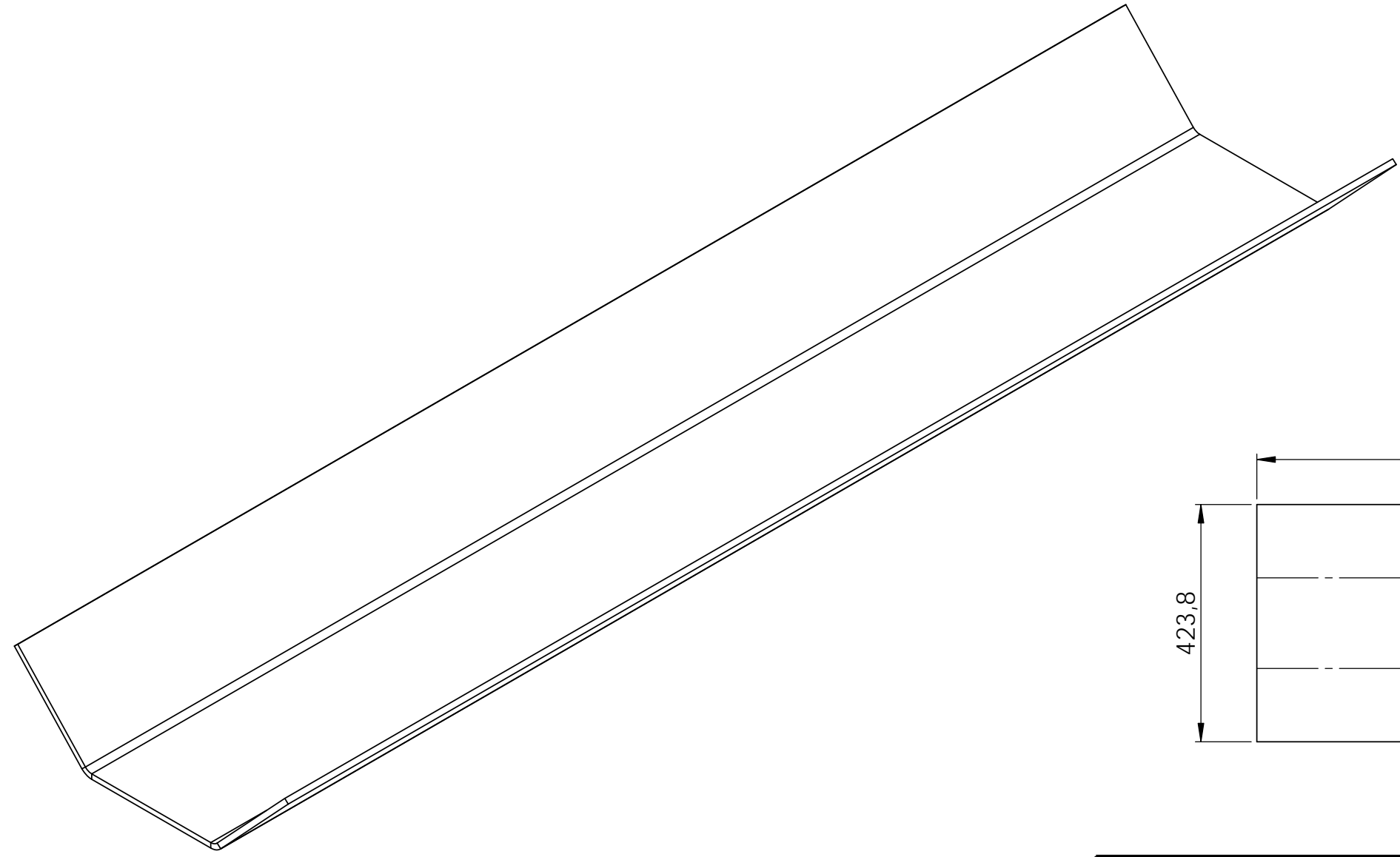
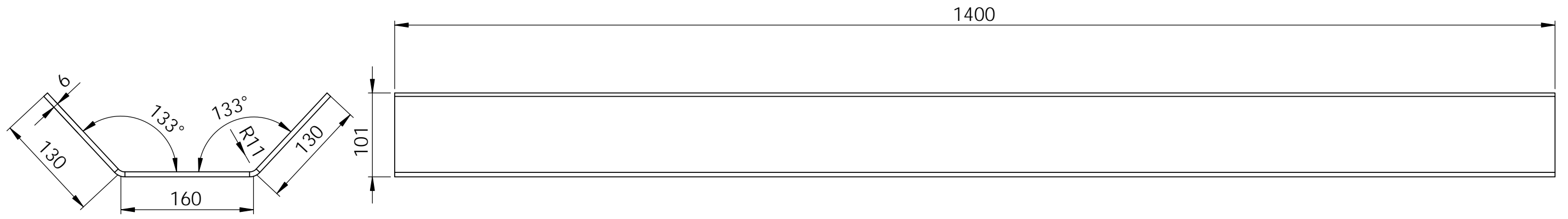

UNLESS OTHERWISE SPECIFIED: DIMENSIONS ARE IN MILLIMETERS SURFACE FINISH: TOLERANCES: LINEAR: ANGULAR:				FINISH:		DEBUR AND BREAK SHARP EDGES		DO NOT SCALE DRAWING		REVISION	
DRAWN	NAME	SIGNATURE	DATE					TITLE:			
CHK'D											
APPV'D											
MFG											
Q.A											
				MATERIAL: 1.0037 (S235JR)				DWG NO. BSPN-0412-05		A3	
				WEIGHT: 27.77				SCALE: 1:10		SHEET 1 OF 1	

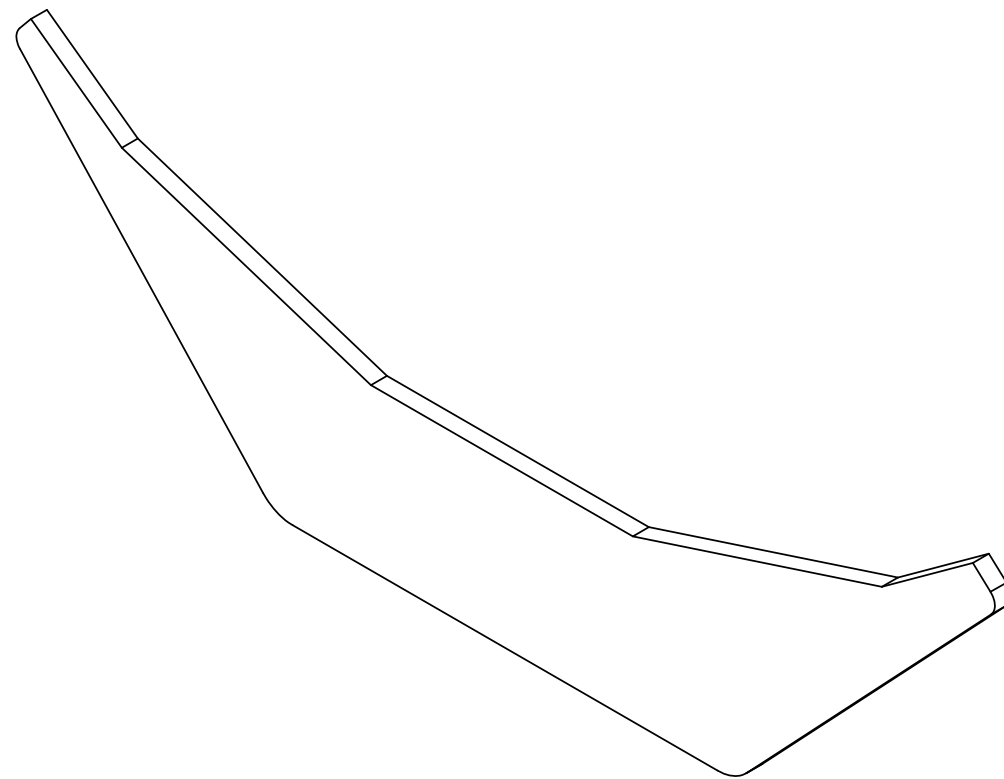
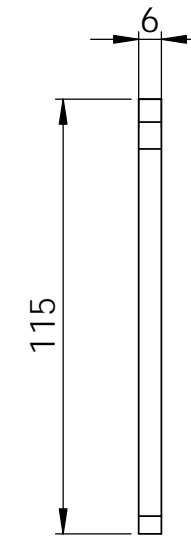
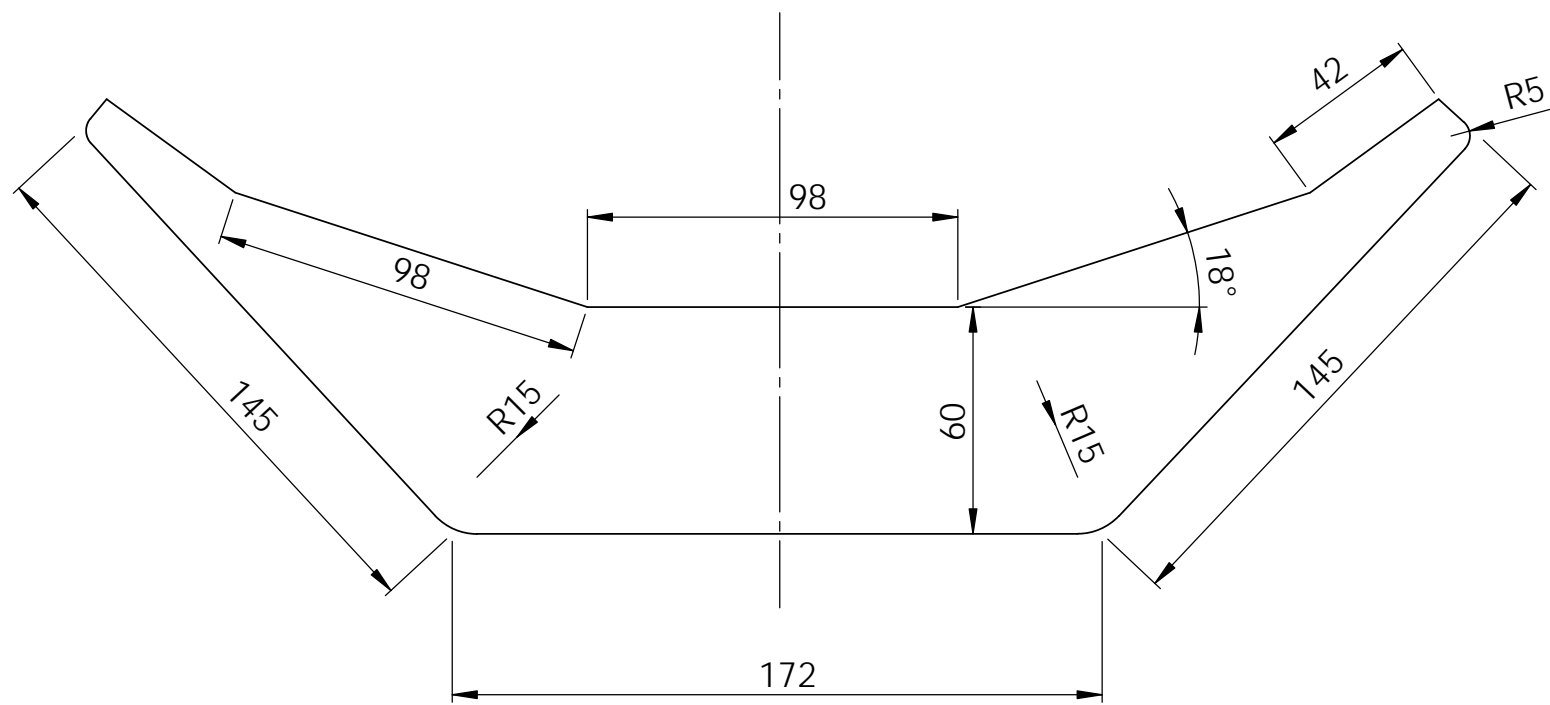

UNLESS OTHERWISE SPECIFIED: DIMENSIONS ARE IN MILLIMETERS				FINISH:		DEBUR AND BREAK SHARP EDGES		DO NOT SCALE DRAWING		REVISION	
SURFACE FINISH:											
TOLERANCES:											
LINEAR:											
ANGULAR:											
	NAME	SIGNATURE	DATE					TITLE:			
DRAWN											
CHK'D											
APPV'D											
MFG											
Q.A				MATERIAL:				DWG NO.		A3	
				1.0037 (S235JR)				BSPN-0412-06			
				WEIGHT: 0.86				SCALE:1:2		SHEET 1 OF 1	

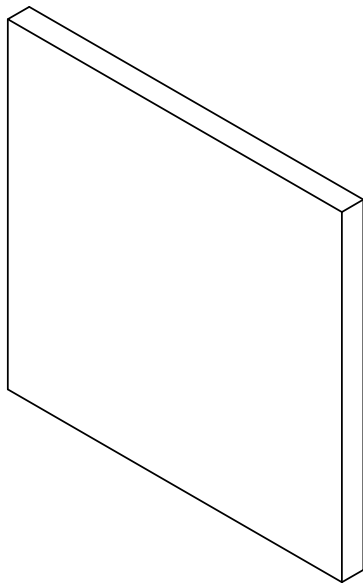
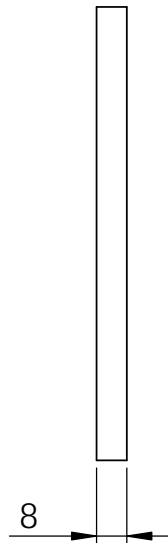
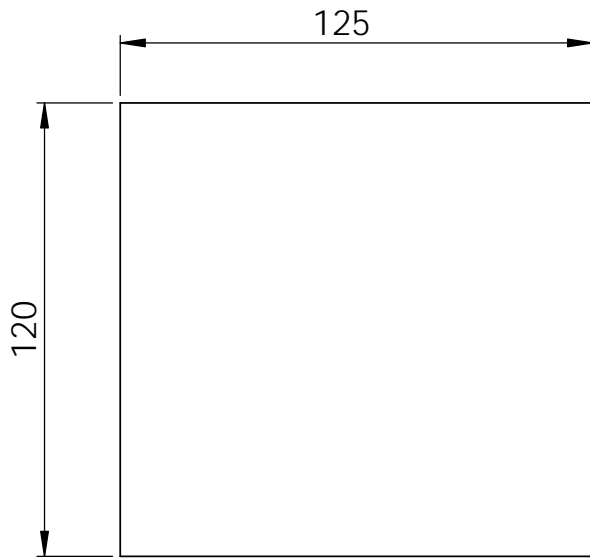

UNLESS OTHERWISE SPECIFIED:
 DIMENSIONS ARE IN MILLIMETERS
 SURFACE FINISH:
 TOLERANCES:
 LINEAR:
 ANGULAR:

FINISH:

DEBUR AND
 BREAK SHARP
 EDGES

DO NOT SCALE DRAWING

REVISION

	NAME	SIGNATURE	DATE		
DRAWN					
CHK'D					
APPV'D					
MFG					
Q.A					
				MATERIAL:	
				1.0037 (S235JR)	
				WEIGHT: 0.94	

TITLE:

DWG NO.

BSPN-0412-08

A4

SCALE:1:2

SHEET 1 OF 1

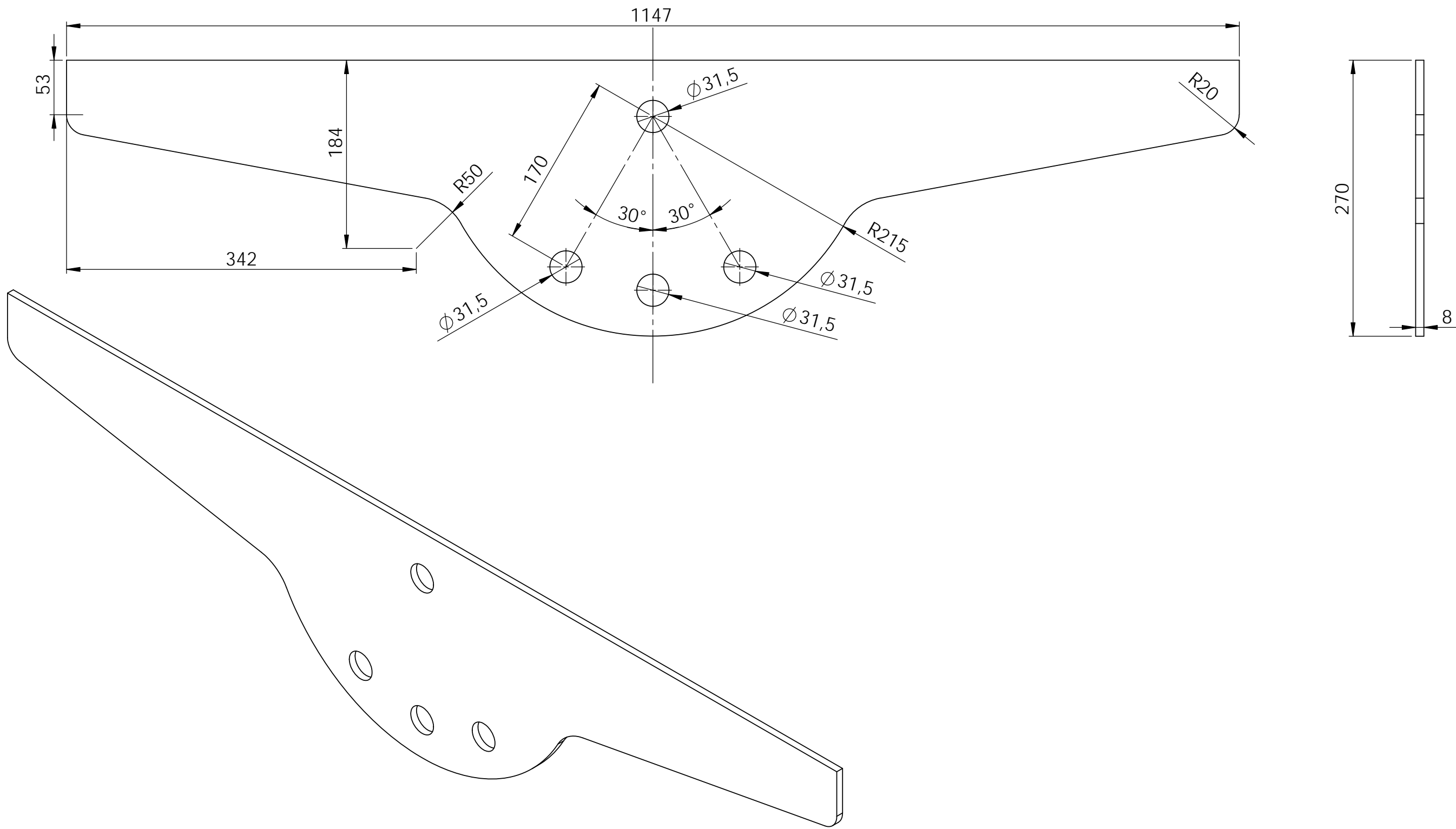

UNLESS OTHERWISE SPECIFIED: DIMENSIONS ARE IN MILLIMETERS				FINISH:		DEBUR AND BREAK SHARP EDGES		DO NOT SCALE DRAWING		REVISION	
SURFACE FINISH:											
TOLERANCES:											
LINEAR:											
ANGULAR:											
	NAME	SIGNATURE	DATE					TITLE:			
DRAWN											
CHK'D											
APPV'D											
MFG											
Q.A				MATERIAL:				DWG NO:		BSPN-0412V2-07	
				1.0037 (S235JR)						A3	
				WEIGHT: 10.49				SCALE:1:5		SHEET 1 OF 1	

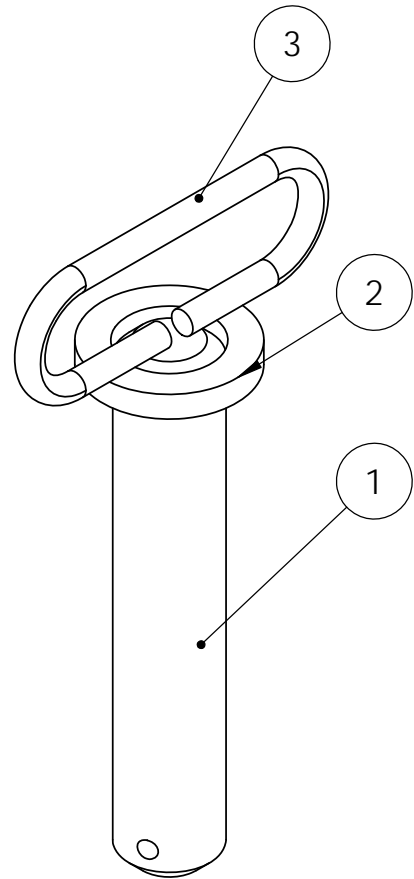
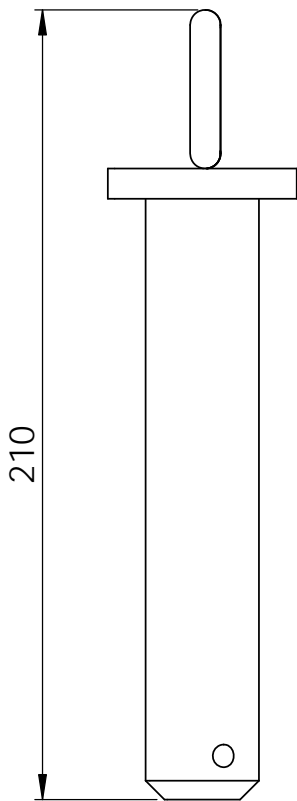
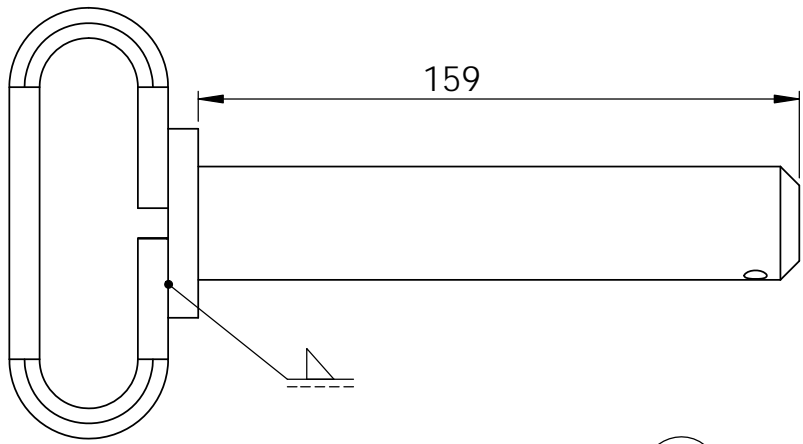
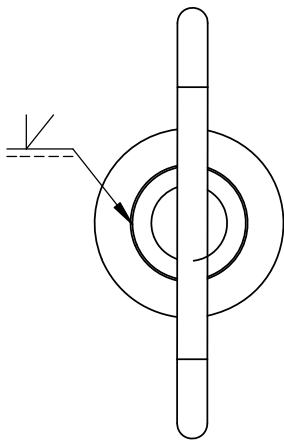

ITEM NO.	PART NUMBER	DESCRIPTION	QTY.
1	BSPN-0412-25		1
2	BSPN-0412-26		1
3	BSPN-0412-24		1

UNLESS OTHERWISE SPECIFIED: DIMENSIONS ARE IN MILLIMETERS SURFACE FINISH: TOLERANCES: LINEAR: ANGULAR:		FINISH: Electrolyzed white		DEBUR AND BREAK SHARP EDGES		DO NOT SCALE DRAWING		REVISION	
NAME		SIGNATURE		DATE		TITLE:			
DRAWN						DWG NO. BSPN-0412-A3			
CHK'D									
APPV'D									
MFG									
O.A.				MATERIAL: Material <not specified>		SCALE:1:5		SHEET 1 OF 1	
				WEIGHT: 1.07				A4	

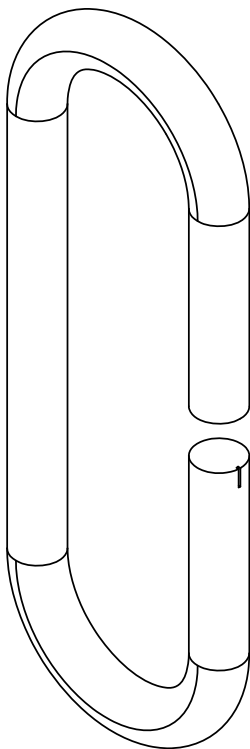
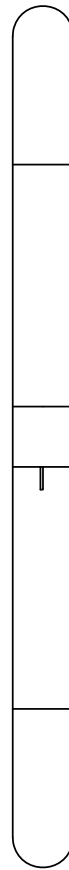
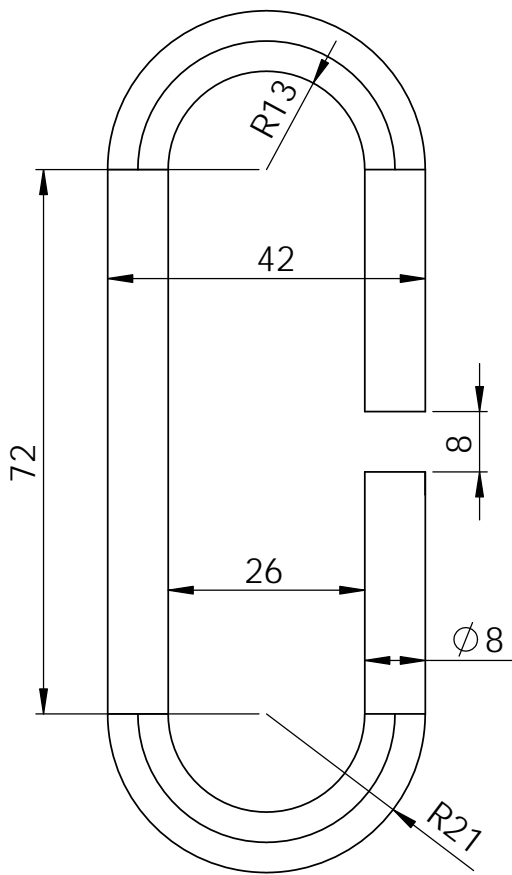

UNLESS OTHERWISE SPECIFIED:
 DIMENSIONS ARE IN MILLIMETERS
 SURFACE FINISH:
 TOLERANCES:
 LINEAR:
 ANGULAR:

FINISH:

DEBUR AND
 BREAK SHARP
 EDGES

DO NOT SCALE DRAWING

REVISION

	NAME	SIGNATURE	DATE		
DRAWN					
CHK'D					
APPV'D					
MFG					
Q.A					
				MATERIAL:	
				1.0037 (S235JR)	
				WEIGHT: 0.10	

TITLE:

DWG NO.

BSPN-0412-24

A4

SCALE:1:2

SHEET 1 OF 1

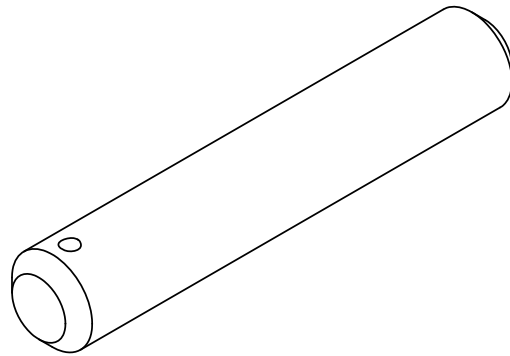
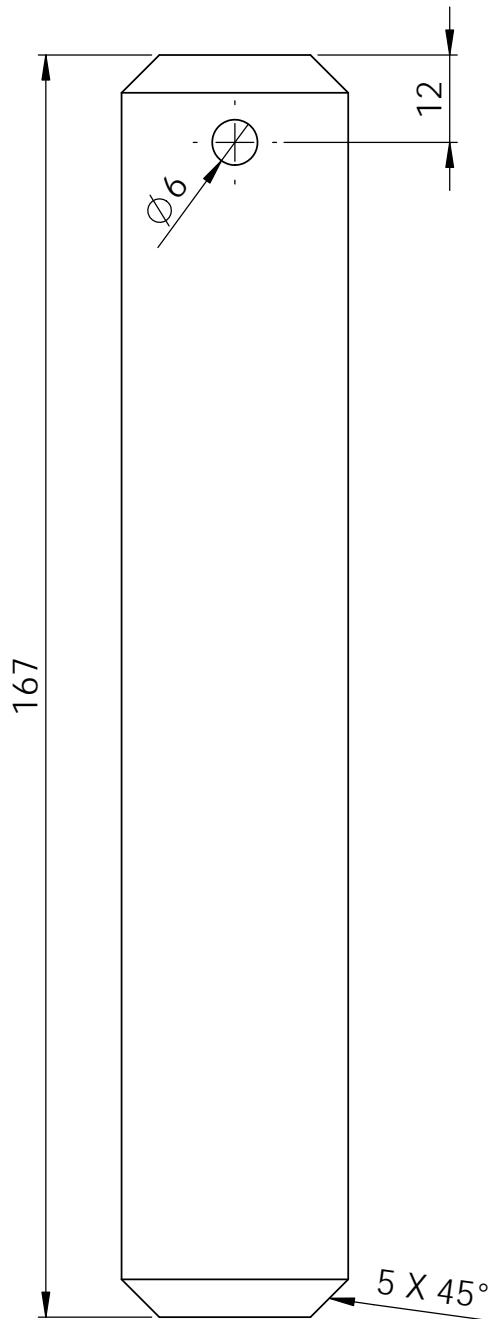
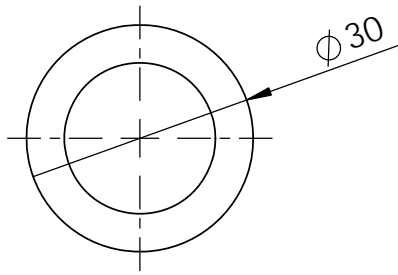

UNLESS OTHERWISE SPECIFIED: DIMENSIONS ARE IN MILLIMETERS SURFACE FINISH: TOLERANCES: LINEAR: ANGULAR:		FINISH:		DEBUR AND BREAK SHARP EDGES		DO NOT SCALE DRAWING		REVISION	
DRAWN		SIGNATURE		DATE		TITLE:			
CHK'D									
APPV'D									
MFG									
O.A				MATERIAL:		DWG NO.		A4	
				1.0037 (S235JR)		BSPN-0412-25			
				WEIGHT: 0.90		SCALE:1:2		SHEET 1 OF 1	

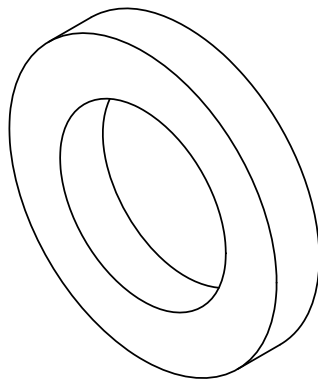
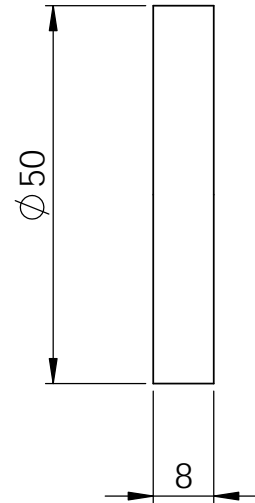
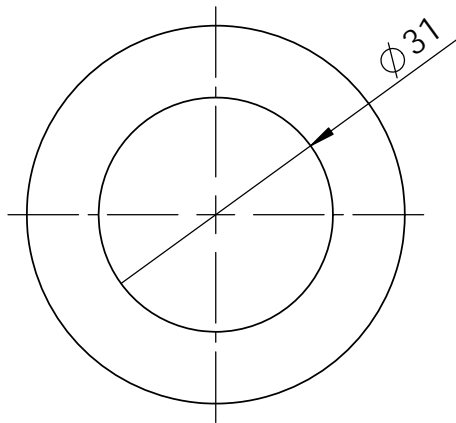

UNLESS OTHERWISE SPECIFIED: DIMENSIONS ARE IN MILLIMETERS SURFACE FINISH: TOLERANCES: LINEAR: ANGULAR:		FINISH:		DEBUR AND BREAK SHARP EDGES		DO NOT SCALE DRAWING		REVISION	
DRAWN		SIGNATURE		DATE		TITLE:			
CHK'D									
APPV'D									
MFG									
O.A									
				MATERIAL: 1.0037 (S235JR)		DWG NO.		BSPN-0412-26	
				WEIGHT: 0.08		SCALE:1:1		SHEET 1 OF 1	
								A4	

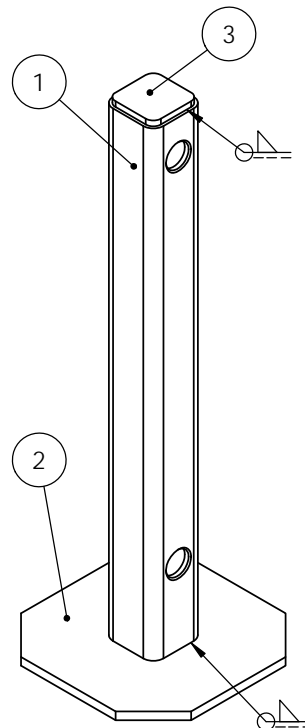
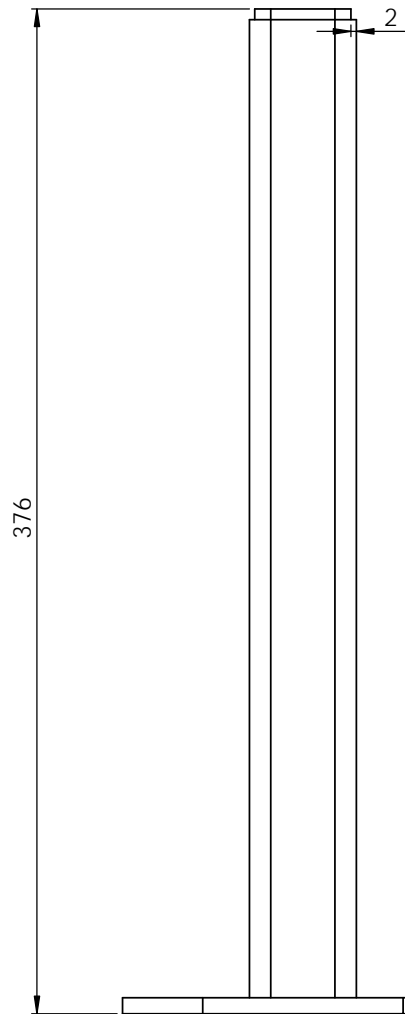
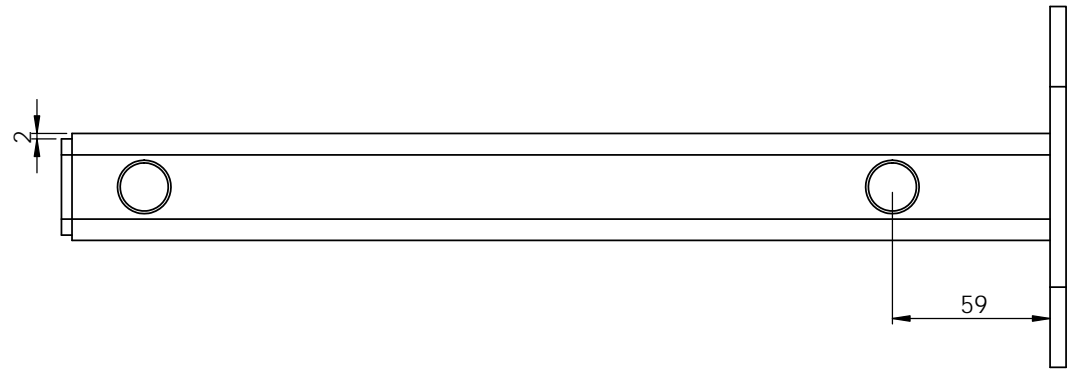
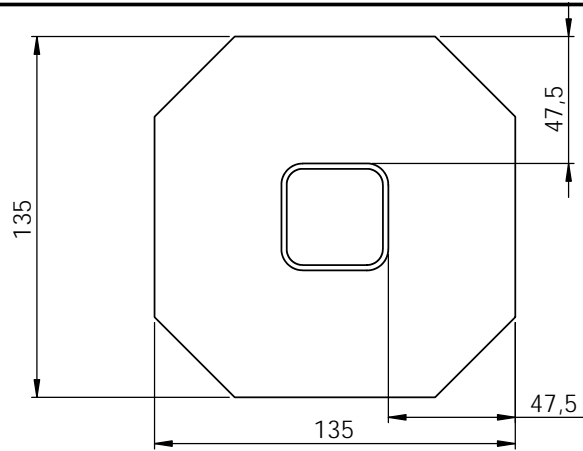

ITEM NO.	PART NUMBER	DESCRIPTION	QTY.
1	BSPN-0412-27		1
2	BSPN-0412-28		1
3	BSPN-0412-29		1

UNLESS OTHERWISE SPECIFIED: DIMENSIONS ARE IN MILLIMETERS		FINISH: White electrolyzed		DEBUR AND BREAK SHARP EDGES		DO NOT SCALE DRAWING		REVISION	
SURFACE FINISH:									
TOLERANCES:									
LINEAR:									
ANGULAR:									
NAME		SIGNATURE		DATE		TITLE:			
DRAWN		CHKD		APPVD		MFG		Q.A	
						MATERIAL:		DWG NO. BSPN-0412-A4	
								A3	
						WEIGHT: 2.30		SCALE: 1:5	
								SHEET 1 OF 1	

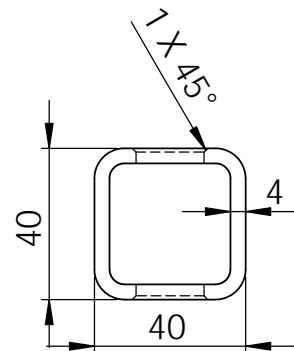
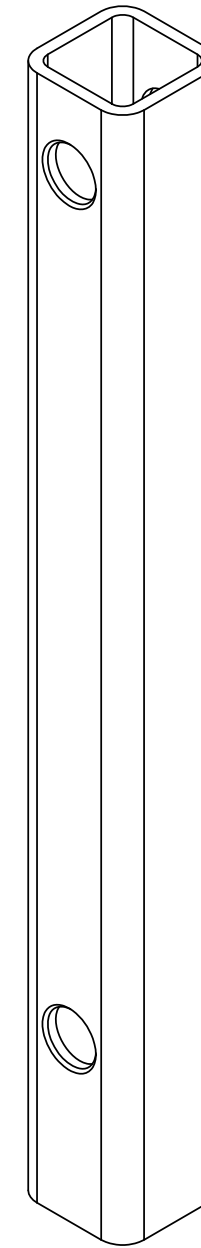
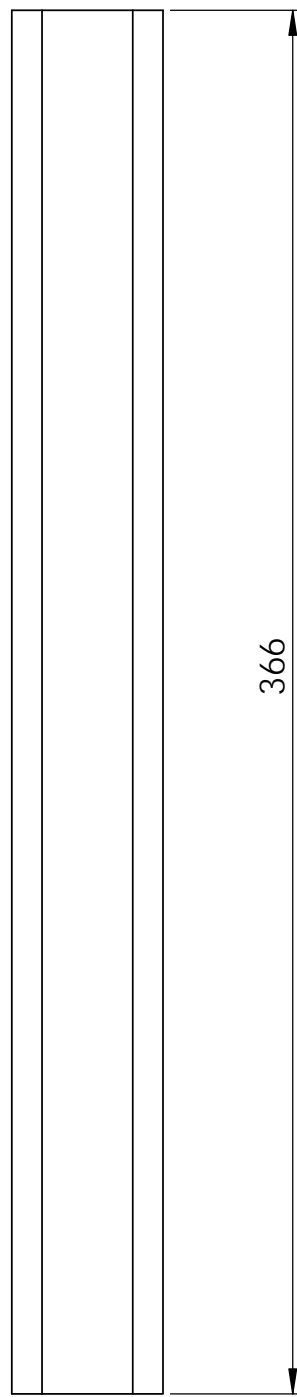
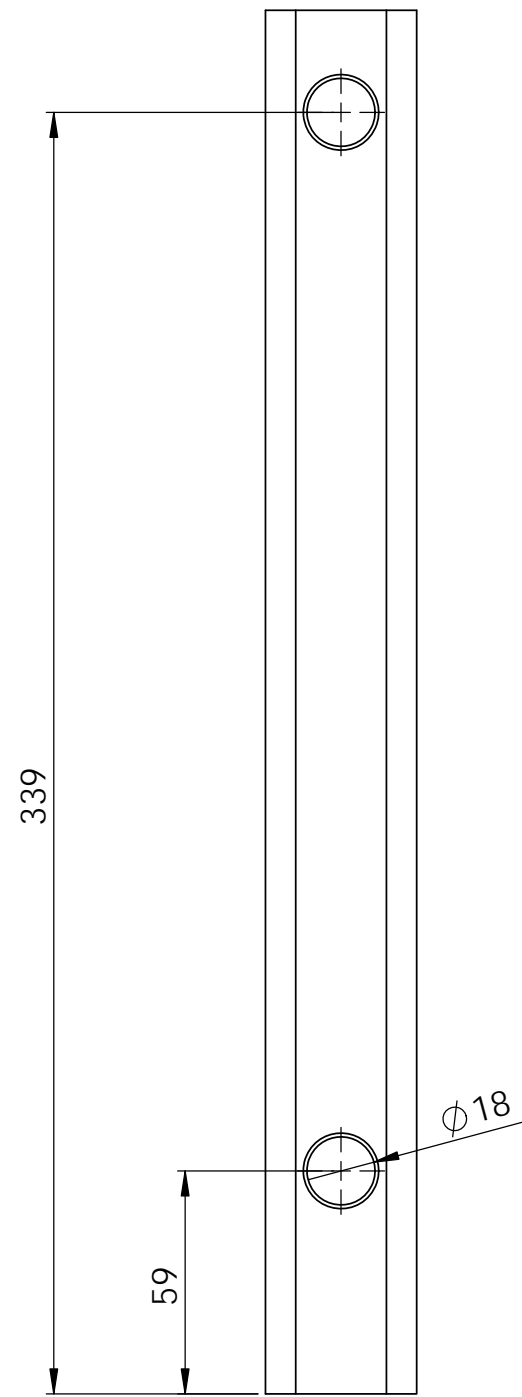

UNLESS OTHERWISE SPECIFIED: DIMENSIONS ARE IN MILLIMETERS SURFACE FINISH: TOLERANCES: LINEAR: ANGULAR:				FINISH:		DEBUR AND BREAK SHARP EDGES		DO NOT SCALE DRAWING		REVISION	
DRAWN				NAME		SIGNATURE		DATE		TITLE:	
CHK'D											
APPV'D											
MFG											
Q.A								MATERIAL:		DWG NO.	
								1.0037 (S235JR)		BSPN-0412-27	
								WEIGHT: 1.49		SCALE:1:5	
										SHEET 1 OF 1	
										A3	

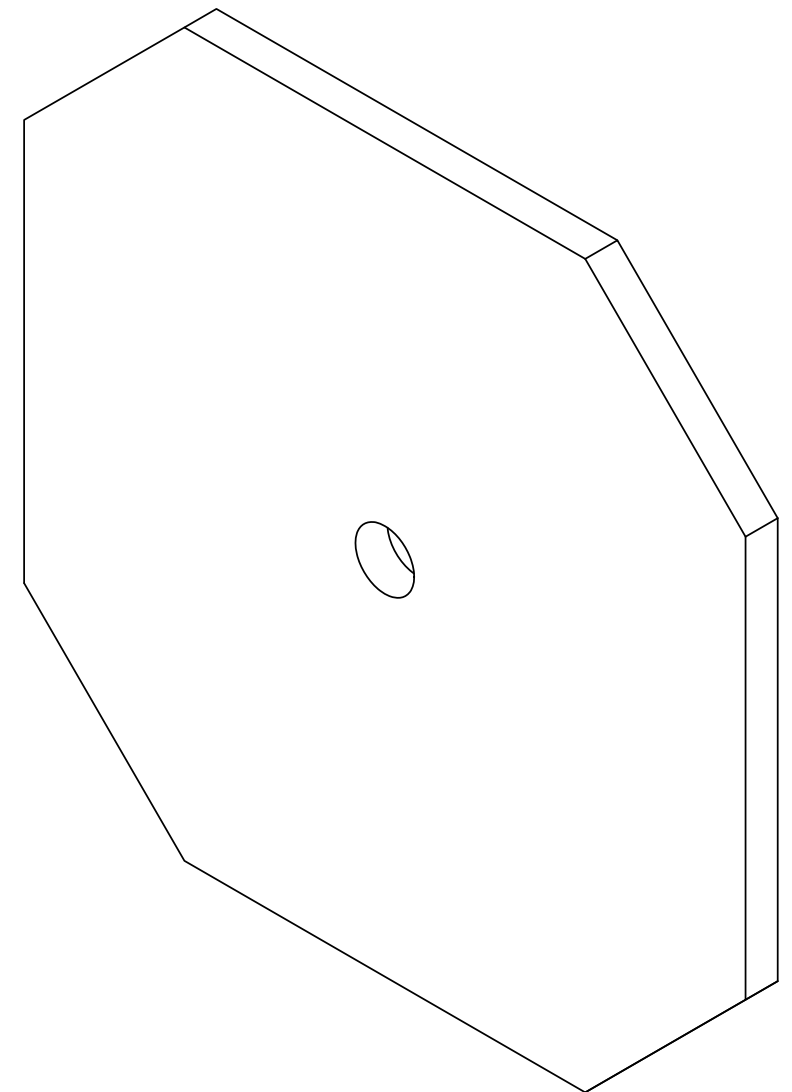
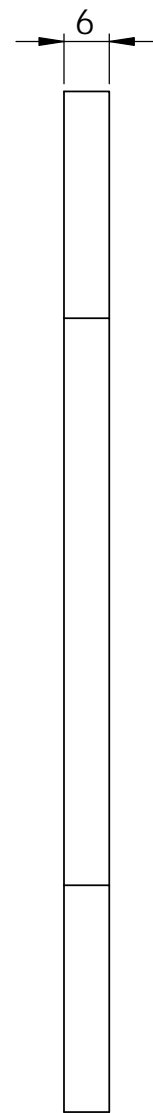
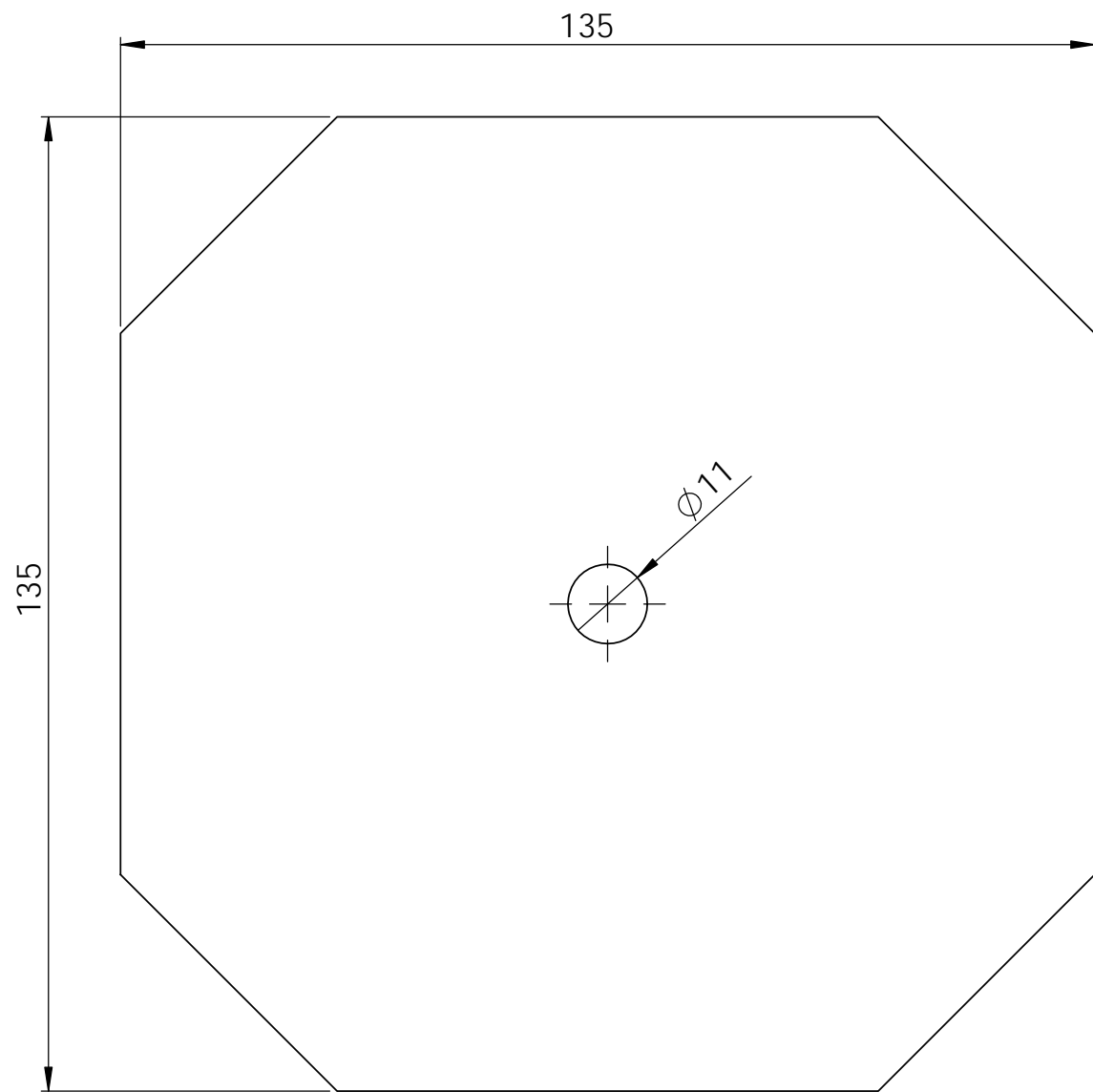

UNLESS OTHERWISE SPECIFIED: DIMENSIONS ARE IN MILLIMETERS SURFACE FINISH: TOLERANCES: LINEAR: ANGULAR:				FINISH:		DEBUR AND BREAK SHARP EDGES		DO NOT SCALE DRAWING		REVISION		
								TITLE:				
DRAWN	NAME	SIGNATURE	DATE					DWG NO. BSPN-0412-28				A3
CHK'D												
APPV'D												
MFG												
Q.A												
				MATERIAL: 1.0037 (S235JR)				SCALE:1:1		SHEET 1 OF 1		
				WEIGHT: 0.76								

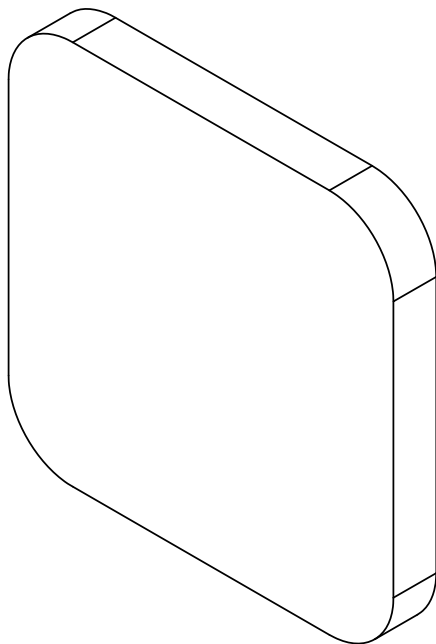
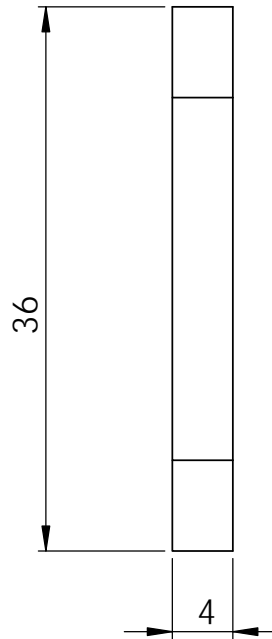
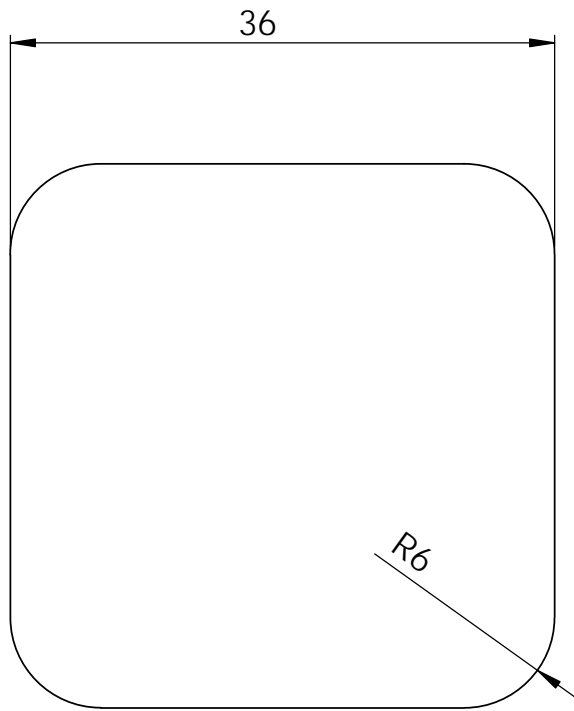

UNLESS OTHERWISE SPECIFIED:
 DIMENSIONS ARE IN MILLIMETERS
 SURFACE FINISH:
 TOLERANCES:
 LINEAR:
 ANGULAR:

FINISH:

DEBUR AND
 BREAK SHARP
 EDGES

DO NOT SCALE DRAWING

REVISION

	NAME	SIGNATURE	DATE		
DRAWN					
CHK'D					
APPV'D					
MFG					
Q.A					
				MATERIAL:	
				1.0037 (S235JR)	
				WEIGHT: 0.04	

TITLE:		DWG NO.	BSPN-0412-29	A4
		SCALE: 2:1		

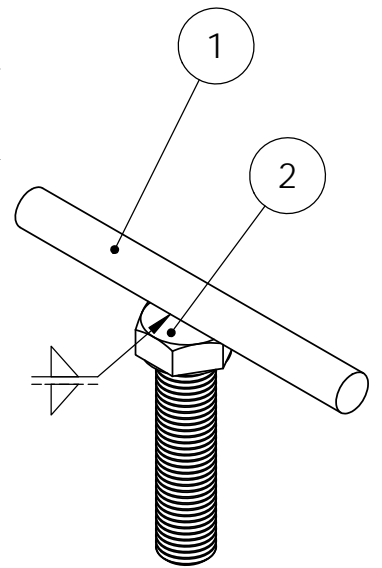
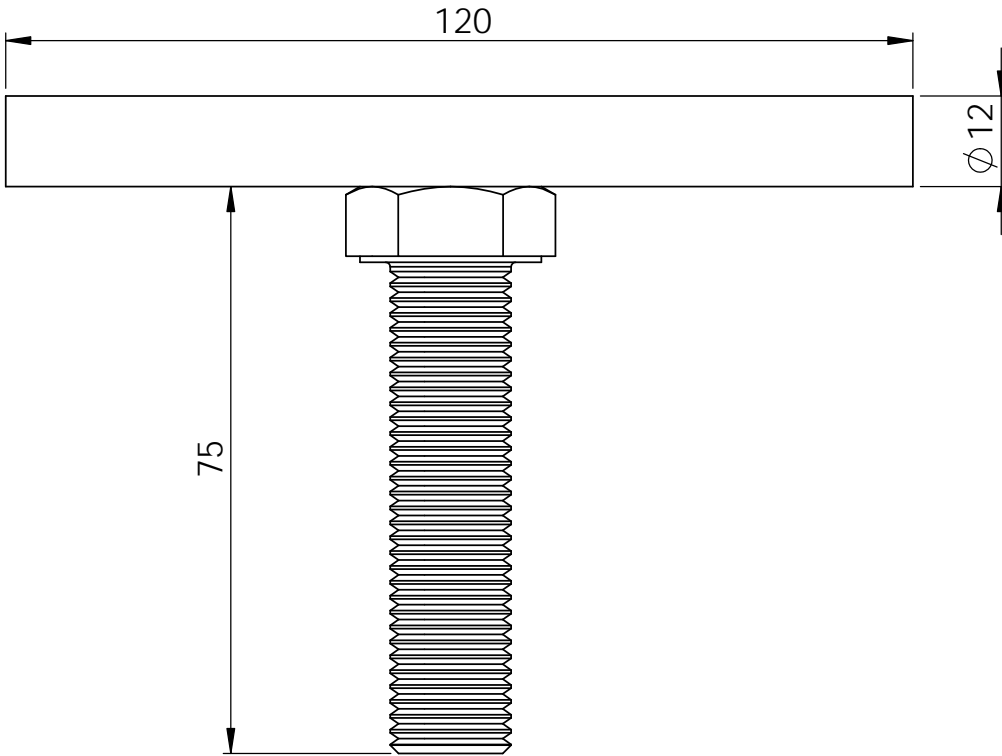
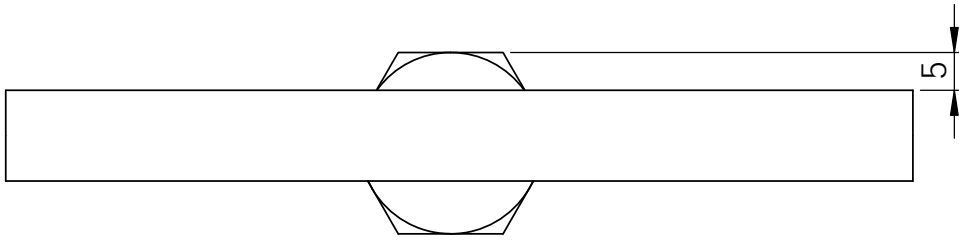

ITEM NO.	PART NUMBER	DESCRIPTION	QTY.
1	F12X120-Handle		1
2	Hex Bolt GradeAB_DIN_ISO 4014 - M16 x 65 x 65-S		1

UNLESS OTHERWISE SPECIFIED: DIMENSIONS ARE IN MILLIMETERS SURFACE FINISH: TOLERANCES: LINEAR: ANGULAR:		FINISH: White Electrolyzed		DEBUR AND BREAK SHARP EDGES		DO NOT SCALE DRAWING		REVISION	
NAME		SIGNATURE		DATE		TITLE:			
DRAWN						DWG NO. BSPN-0412-H1			
CHK'D									
APPV'D									
MFG									
O.A									
				MATERIAL:		SCALE:1:2		SHEET 1 OF 1	
				WEIGHT: 0.12				A4	

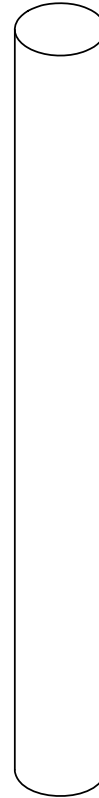
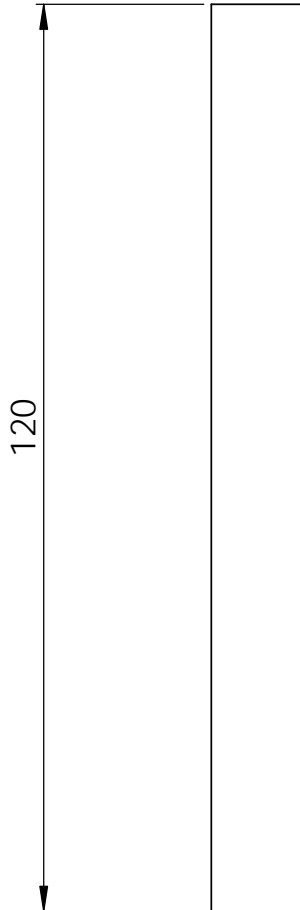
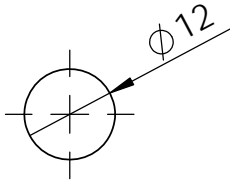

UNLESS OTHERWISE SPECIFIED:
 DIMENSIONS ARE IN MILLIMETERS
 SURFACE FINISH:
 TOLERANCES:
 LINEAR:
 ANGULAR:

FINISH:

DEBUR AND
 BREAK SHARP
 EDGES

DO NOT SCALE DRAWING

REVISION

	NAME	SIGNATURE	DATE		
DRAWN					
CHK'D					
APPV'D					
MFG					
Q.A					
				MATERIAL:	
				1.0037 (S235JR)	
				WEIGHT: 0.11	

TITLE:

DWG NO.

F12X120-Handle

A4

SCALE:1:2

SHEET 1 OF 1

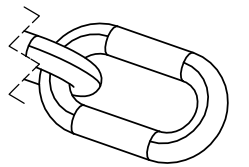
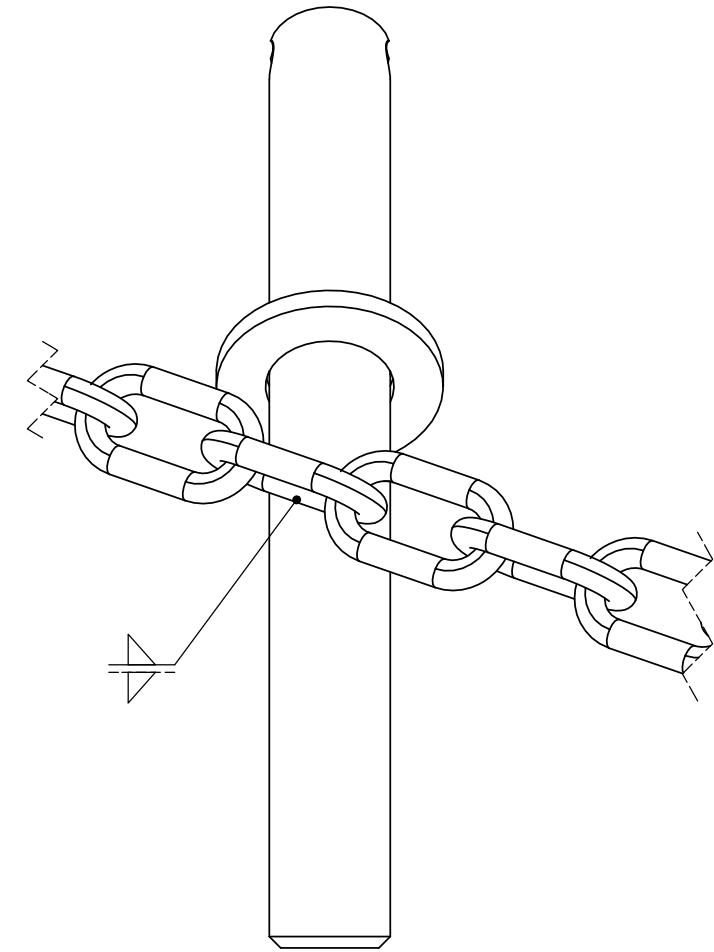
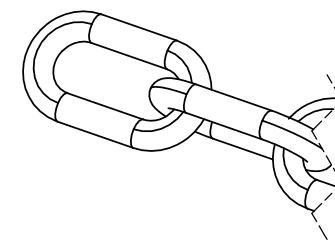
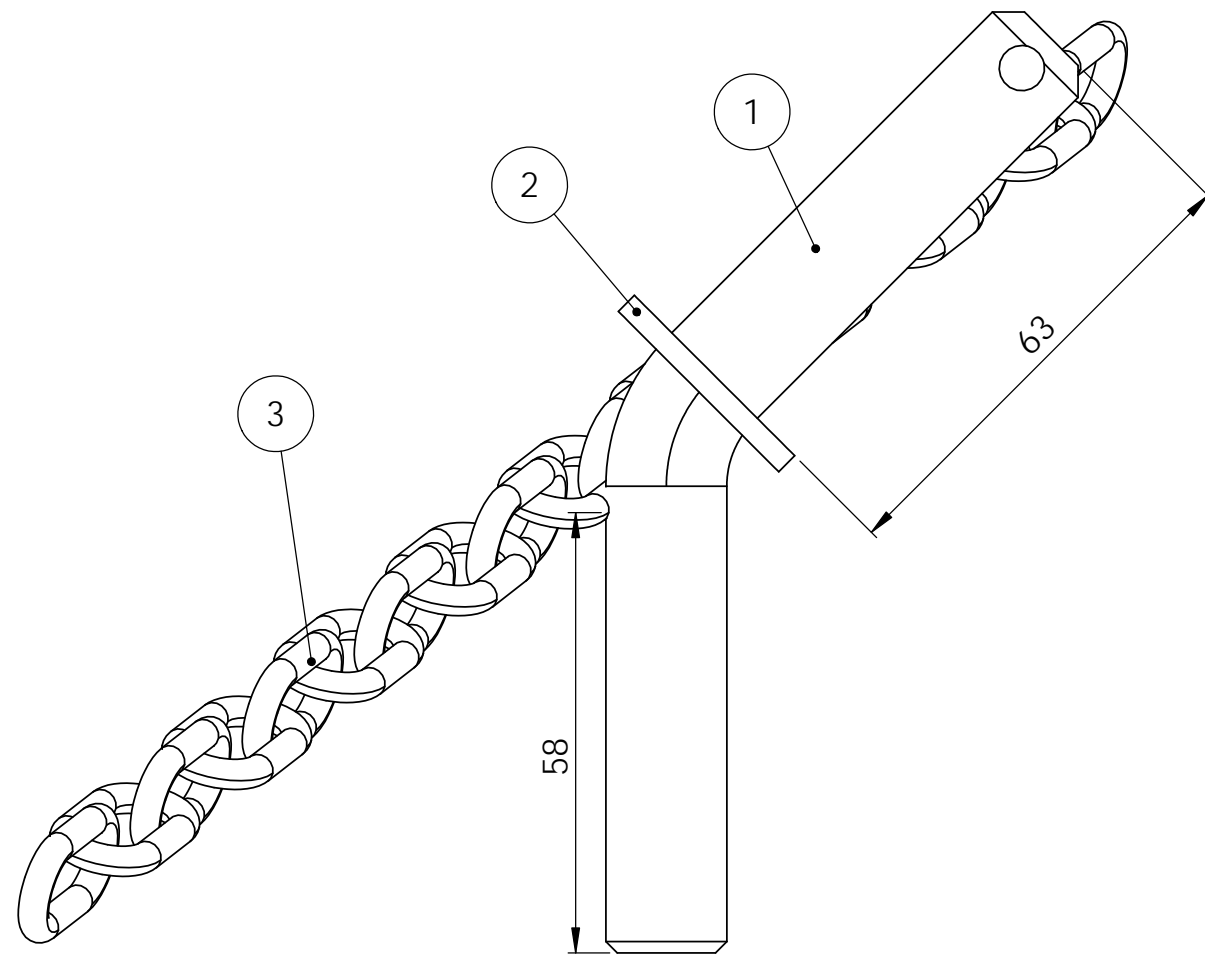

UNLESS OTHERWISE SPECIFIED: DIMENSIONS ARE IN MILLIMETERS SURFACE FINISH: TOLERANCES: LINEAR: ANGULAR:				FINISH: White Electrolyzed		DEBUR AND BREAK SHARP EDGES		DO NOT SCALE DRAWING		REVISION	
DRAWN				NAME		SIGNATURE		DATE		TITLE:	
CHK'D											
APPV'D											
MFG											
Q.A								MATERIAL:		DWG NO. BSPN-0412-A5	
								WEIGHT: 0.34		SCALE:1:5	
										SHEET 1 OF 1	

ITEM NO.	PART NUMBER	DESCRIPTION	QTY.
1	BSPN-0412-30		1
2	BSP-Washer16		1
3	BSP-F4DIN5685A	Standard chain DIN5685A-f4mm	1

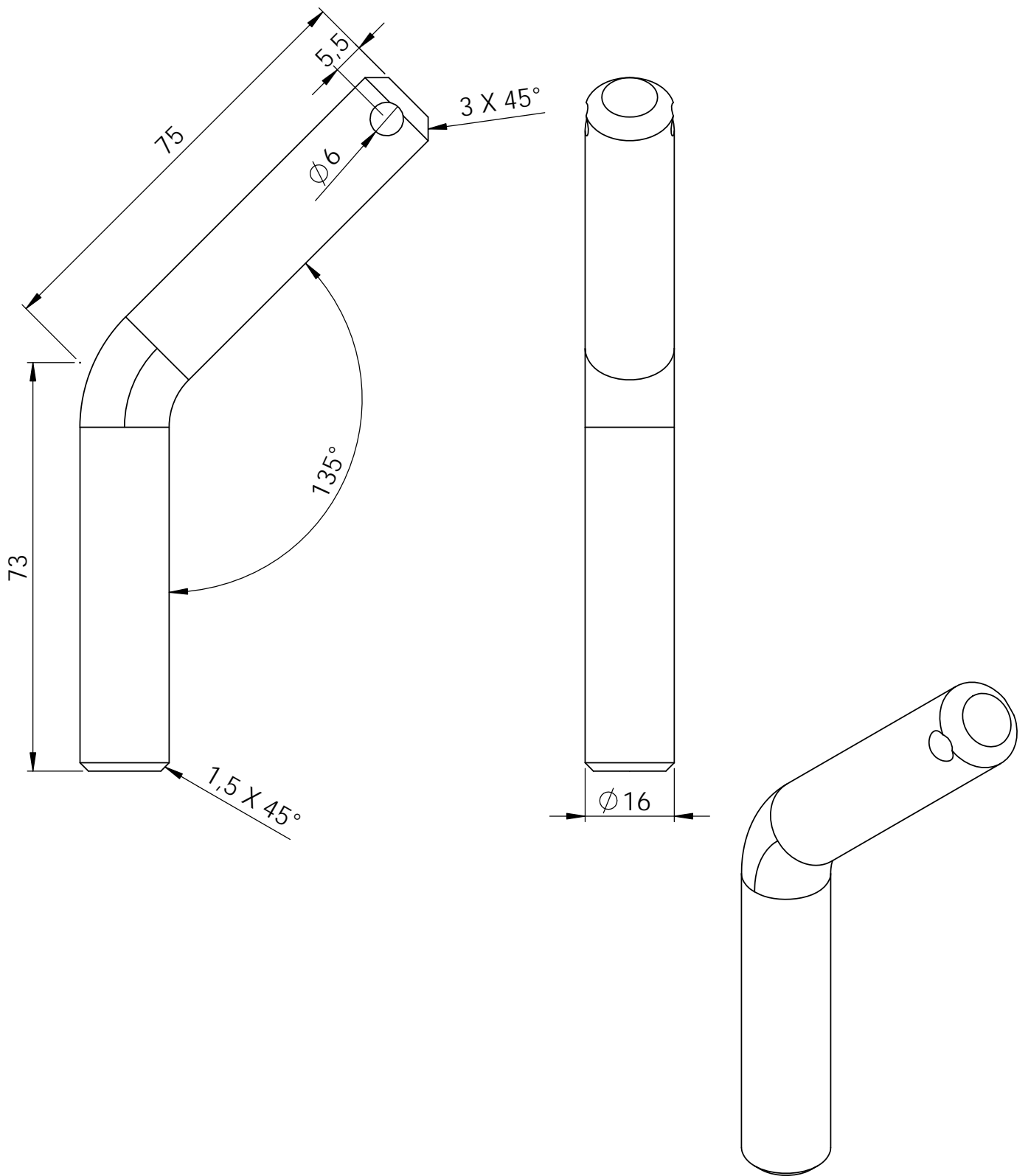

UNLESS OTHERWISE SPECIFIED:
 DIMENSIONS ARE IN MILLIMETERS
 SURFACE FINISH:
 TOLERANCES:
 LINEAR:
 ANGULAR:

FINISH:

DEBUR AND
 BREAK SHARP
 EDGES

DO NOT SCALE DRAWING

REVISION

	NAME	SIGNATURE	DATE		
DRAWN					
CHK'D					
APPV'D					
MFG					
O.A.				MATERIAL:	
				1.0037 (S235JR)	
				WEIGHT: 0.22	

TITLE:

DWG NO.

BSPN-0412-30

A4

SCALE:1:2

SHEET 1 OF 1

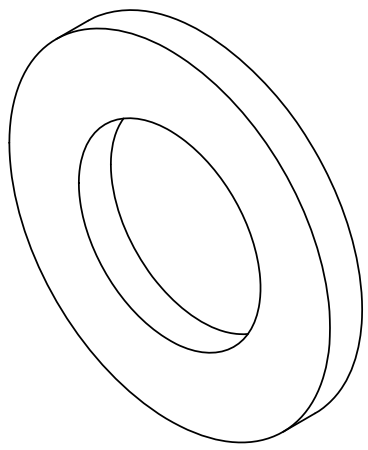
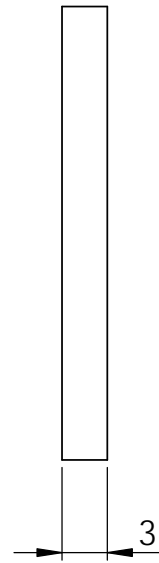
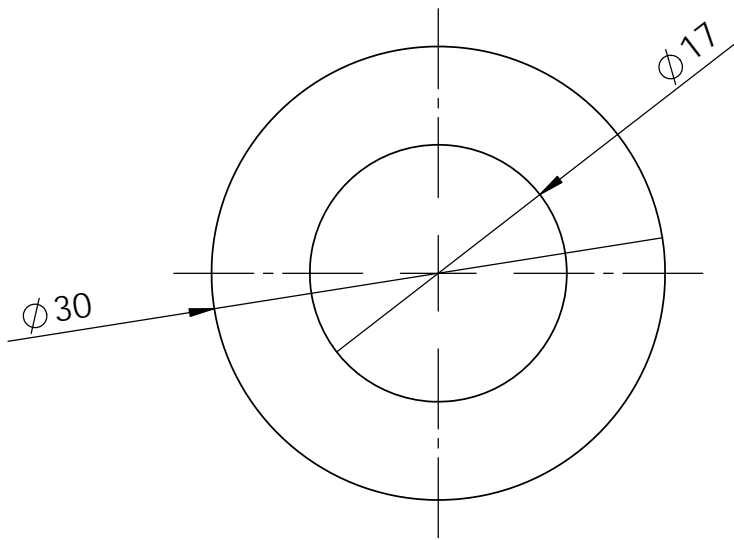

UNLESS OTHERWISE SPECIFIED: DIMENSIONS ARE IN MILLIMETERS SURFACE FINISH: TOLERANCES: LINEAR: ANGULAR:		FINISH:		DEBUR AND BREAK SHARP EDGES		DO NOT SCALE DRAWING		REVISION	
						TITLE:			
DRAWN		SIGNATURE		DATE					
CHK'D									
APPV'D									
MFG									
O.A				MATERIAL:		DWG NO. BSP-Washer16		A4	
				WEIGHT:		SCALE:2:1		SHEET 1 OF 1	

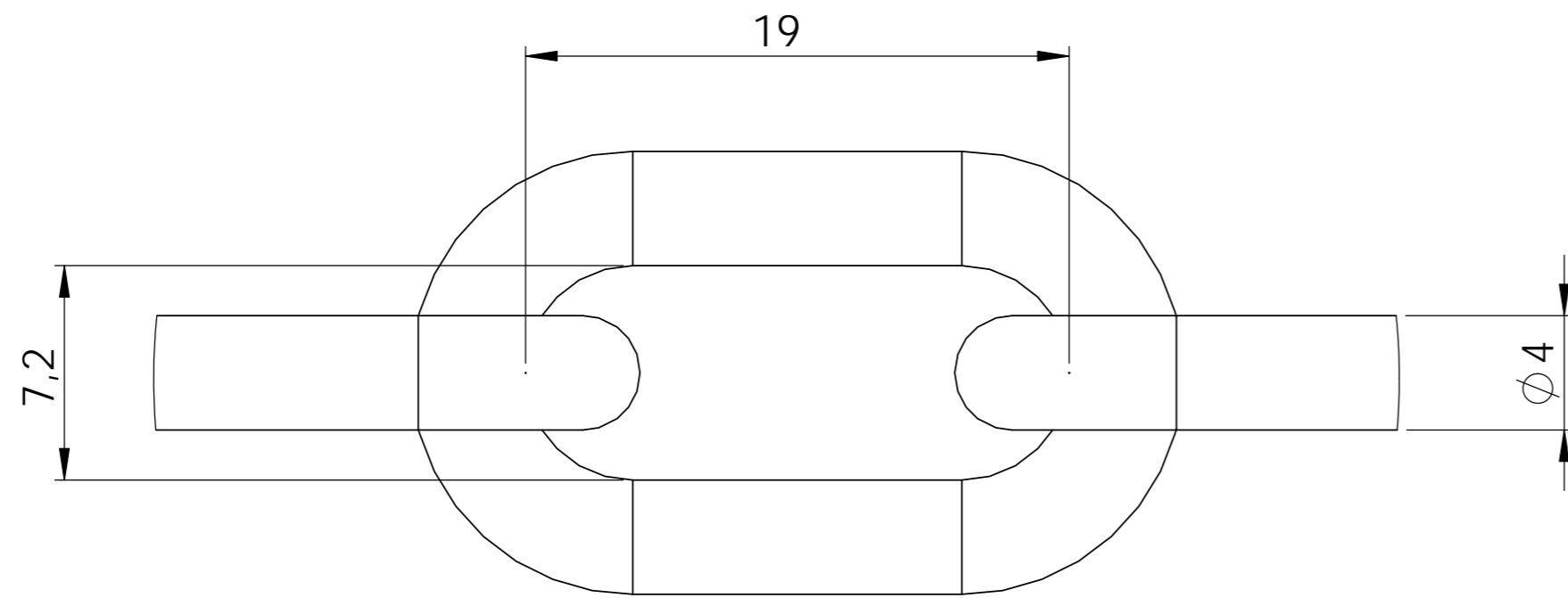
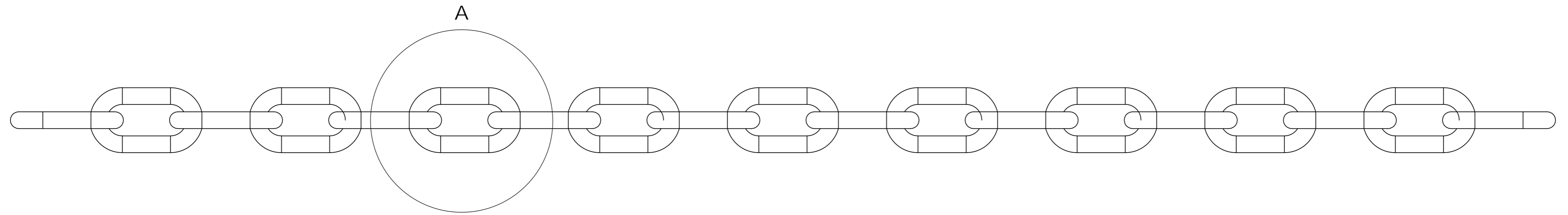

DETAIL A
SCALE 3 : 1

Use standard chain
DIN 5685A - f4mm
Tottal length 361mm
19 links

UNLESS OTHERWISE SPECIFIED: DIMENSIONS ARE IN MILLIMETERS SURFACE FINISH: TOLERANCES: IT12 LINEAR: ANGULAR:				FINISH:		DEBUR AND BREAK SHARP EDGES		DO NOT SCALE DRAWING		REVISION			
								TITLE:					
DRAWN				NAME		SIGNATURE						DATE	
CHK'D													
APPV'D													
MFG													
Q.A								MATERIAL:		DWG NO: BSP-F4DIN5685A			
								WEIGHT: 0.11		SCALE:1:5			
										SHEET 1 OF 1			
										A3			

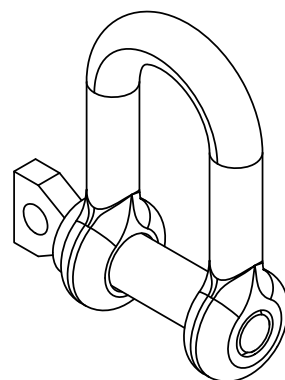
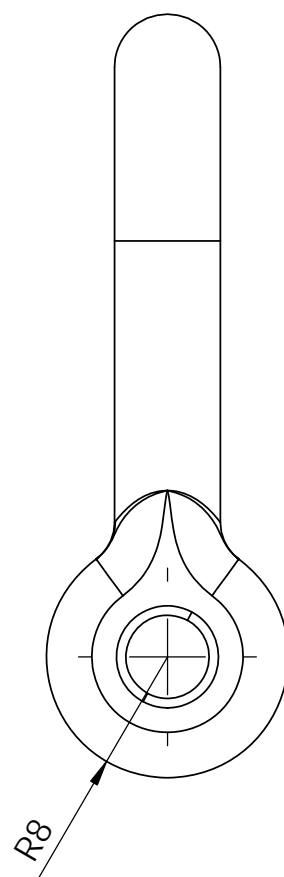
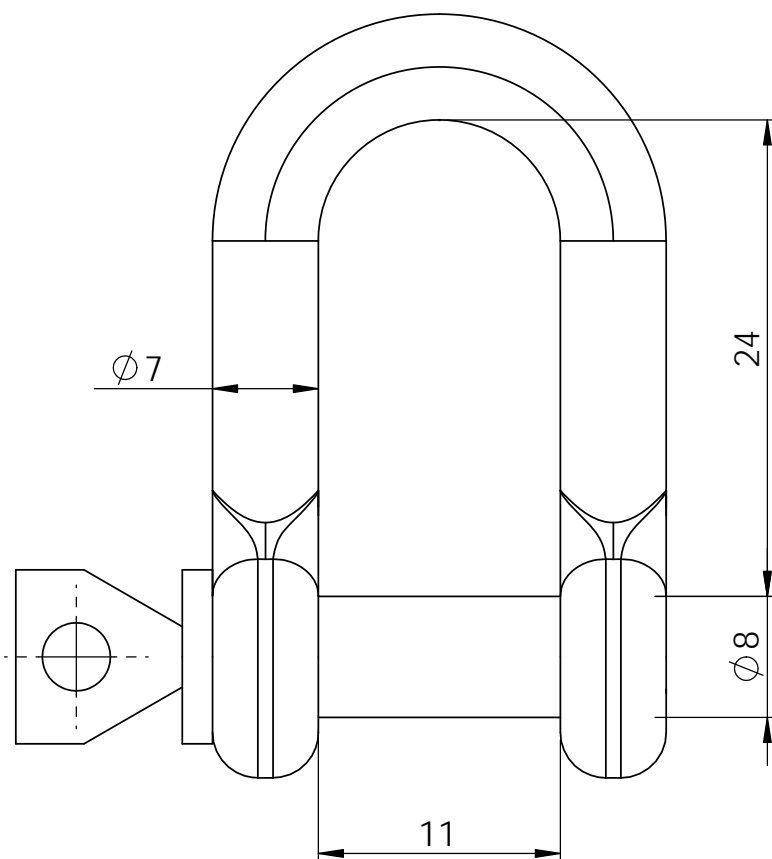

UNLESS OTHERWISE SPECIFIED:
 DIMENSIONS ARE IN MILLIMETERS
 SURFACE FINISH:
 TOLERANCES: IT12
 LINEAR:
 ANGULAR:

FINISH:

DEBUR AND
 BREAK SHARP
 EDGES

DO NOT SCALE DRAWING

REVISION

	NAME	SIGNATURE	DATE		
DRAWN					
CHK'D					
APPV'D					
MFG					
Q.A				MATERIAL:	
				WEIGHT:	

TITLE:		Use standard shackle DIN 82101A-M8	
DWG NO.		SP21603	
SCALE:1:1		SHEET 1 OF 1	
		A4	

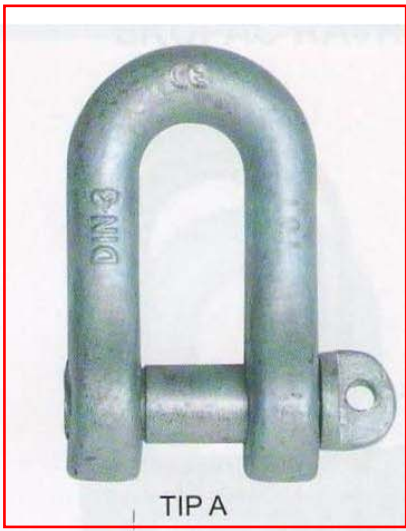

TIP A



TIP B



TIP C

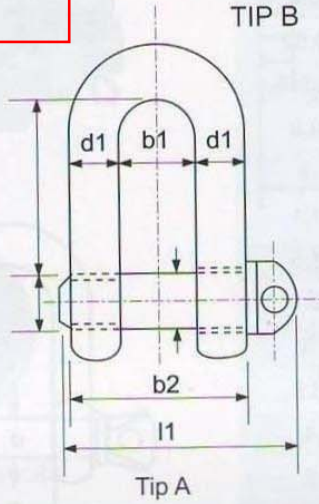
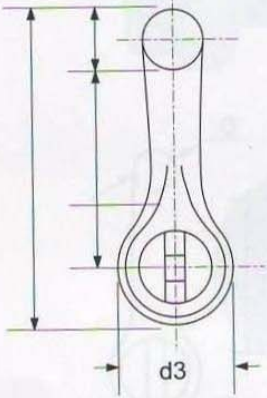

Tip A

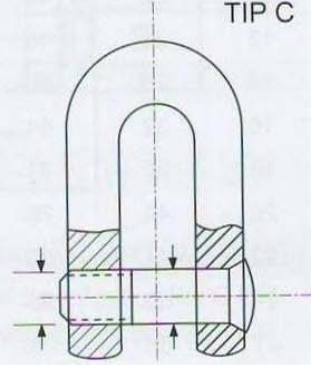

Tip B

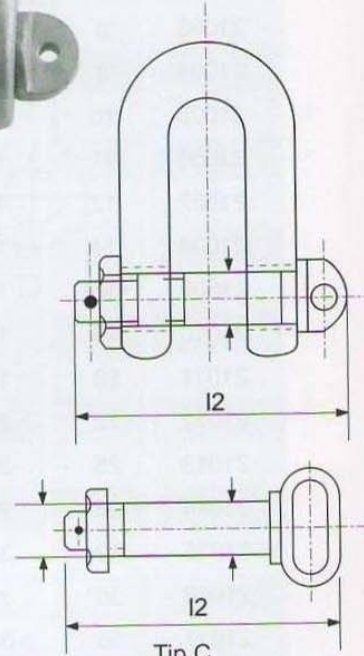

Tip C

Šifra	Nominalna veličina			Nosivost		Dimenzije (mm)														Težina		
	A	B	C	t	kN*	b1	b2	d1	d2	d3	d4	d5	d6	H	h1	h	l1	l2	A	B	C	
21601	0.1	-	-	0.1	1	7	15	4	5	10	M5	5	5.3-0.1	28	15.5	18	24	-	0.013	-	-	
21602	0.16	-	-	0.16	1.6	8	18	5	6	12	M6	6	6.4-0.1	33	18	21	28	-	0.024	-	-	
21603	0.25	-	-	0.25	2.5	11	25	7	8	16	M8	8	8.4-0.2	44	24	28	38	-	0.045	-	-	
21604	0.4	0.4	0.4	0.4	4.0	14	31	8	10	20	M10	10	10.5-0.3	55	30	35	45	58	0.090	0.085	0.100	
21605	0.6	0.6	0.6	0.63	6.3	17	39	10	12	24	M12	12	13-0.5	66	36	42	53	66	0.178	0.165	0.180	
21606	1	1	1	1	10	21	49	13	15	32	M16	16	17-0.5	88	49	57	64	80	0.360	0.340	0.390	
21607	1.6	1.6	1.6	1.6	16	27	63	17	19	40	M20	20	21-0.5	110	61	71	85	100	0.750	0.720	0.800	
21608	2	2	2	2	20	30	70	19	21	44	M22	22	23-0.5	121	67	78	93	110	1.000	0.960	1.080	
21609	2.5	2.5	2.5	2.5	25	33	78	21	23	48	M24	24	25-0.5	132	73	85	103	122	1.320	1.250	1.400	
21610	3	3	3	3.15	31.5	33	90	24	26	64	M27	27	23-0.5	150	83.5	97	120	140	1.850	1.750	2.000	
21611	4	4	4	4	40	42	100	27	29	60	M30	30	31-0.5	165	91	106	130	150	2.500	2.400	2.700	
21612	5	5	5	5	50	47	111	30	33	72	M36	36	37-0.5	198	111	129	144	172	4.000	3.800	4.300	
21613	6	6	6	6.3	63	53	126	34	37	78	M39	39	40-0.5	215	119.5	139	160	190	5.400	5.200	5.800	
21614	8	8	8	8	80	60	142	38	41	90	M45	45	46-0.5	248	139.5	162	182	217	7.900	7.600	8.500	
21615	10	10	10	10	100	66	155	42	45	96	M48	48	50-1	264	147	171	200	235	10.00	9.700	10.800	
21616	12	12	12	12.5	125	73	173	47	50	104	M52	52	54-1	286	158	184	216	254	13.500	13.000	14.000	
21617	16	16	16	16	160	81	193	52	55	120	M60	60	62-1	330	185	215	245	285	19.200	19.100	20.500	
21618	20	20	20	20	200	90	214	58	61	136	M68	68	70-1	374	211	245	270	311	28.000	27.500	29.500	
21619	25	-	25	25	250	100	226	63	67	144	M72	72	74-1	396	221	257	324	371	34.000	-	36.000	

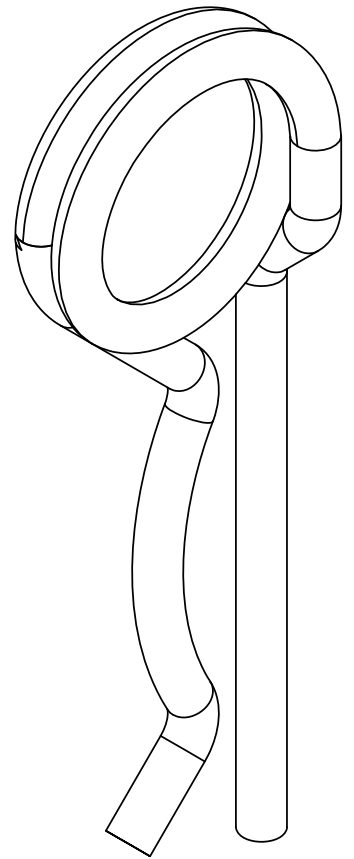
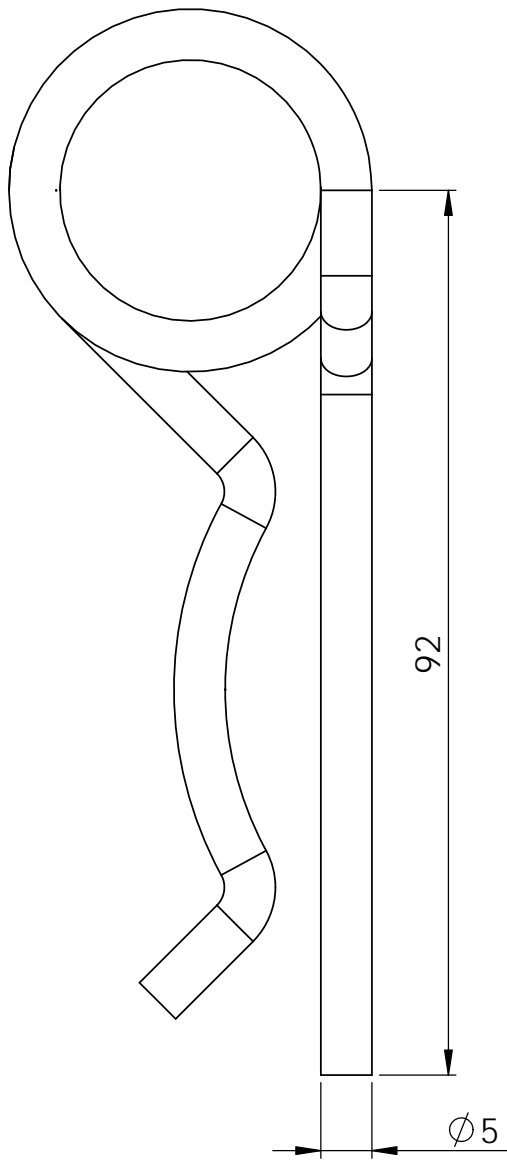

Use standard pin
DIN 11024 - f5mm

UNLESS OTHERWISE SPECIFIED:
DIMENSIONS ARE IN MILLIMETERS
SURFACE FINISH:
TOLERANCES: IT12
LINEAR:
ANGULAR:

FINISH:

DEBUR AND
BREAK SHARP
EDGES

DO NOT SCALE DRAWING

REVISION

	NAME	SIGNATURE	DATE		
DRAWN					
CHK'D					
APPV'D					
MFG					
Q.A					
				MATERIAL:	
					1.0503 (C45)
				WEIGHT:	

TITLE:

DWG NO.

BSP-DIN11024-27524

A4

SCALE:1:2

SHEET 1 OF 1

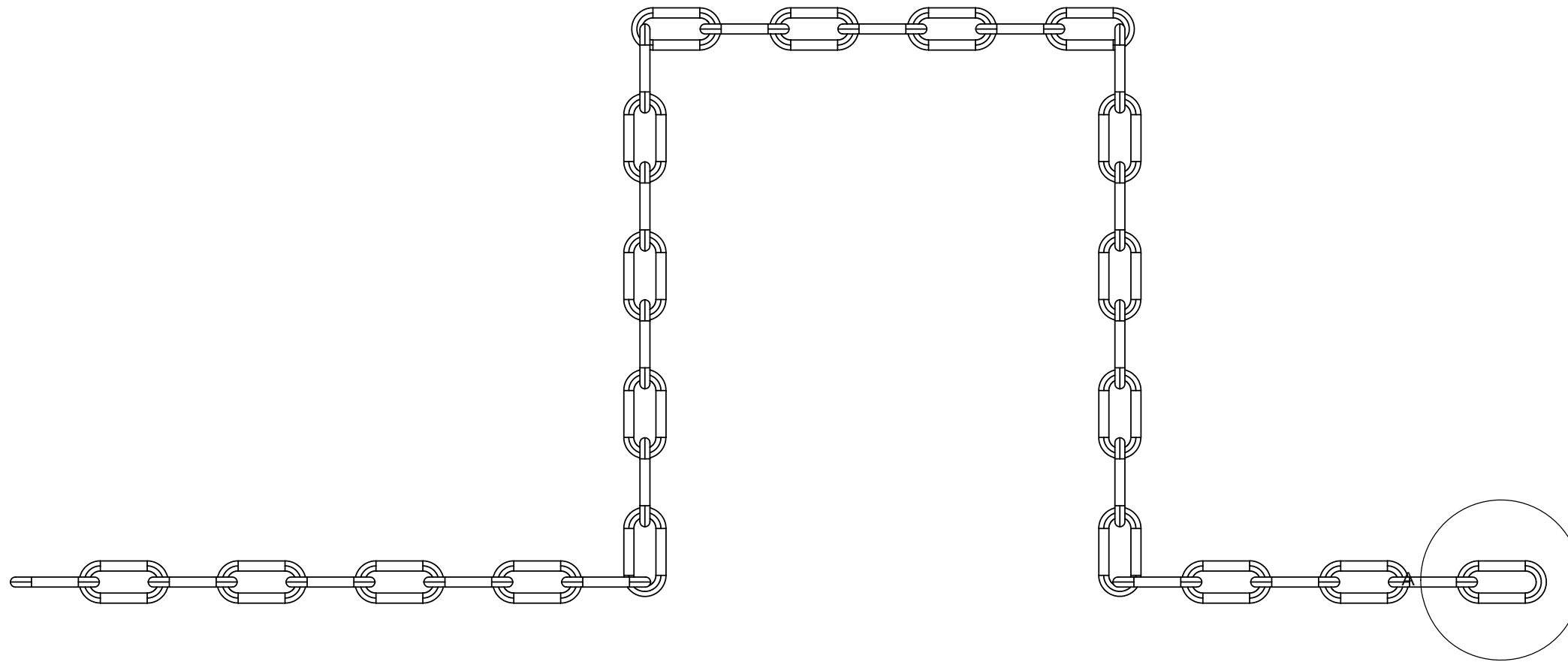

DETAIL A
SCALE 2 : 1

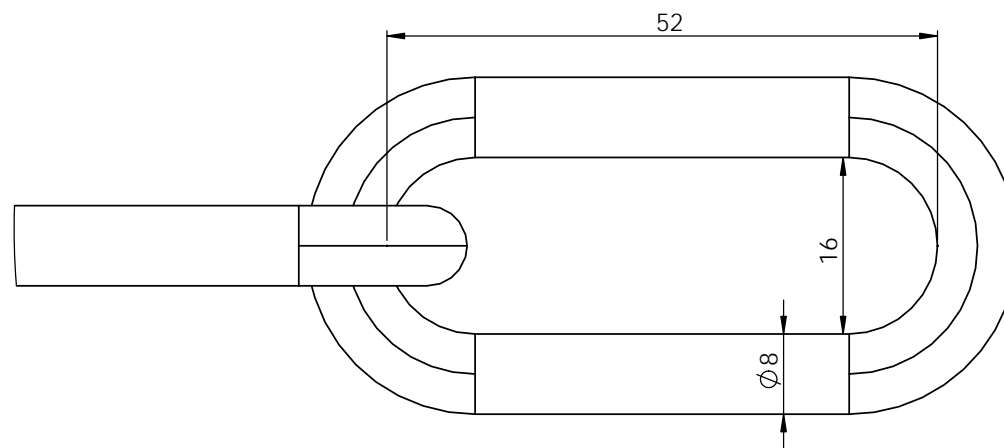

Standard Chain f8mm DIN 5685C

Tottal lenght 1976mm
38 links

UNLESS OTHERWISE SPECIFIED: DIMENSIONS ARE IN MILLIMETERS				FINISH:		DEBUR AND BREAK SHARP EDGES		DO NOT SCALE DRAWING		REVISION	
SURFACE FINISH:											
TOLERANCES: IT12											
LINEAR:											
ANGULAR:											
	NAME	SIGNATURE	DATE					TITLE:			
DRAWN											
CHK'D											
APP'VD											
MFG											
Q.A								MATERIAL:		DWG NO. BSP-F8DIN5685C A2	
								WEIGHT:		SCALE:1:10 SHEET 1 OF 1	

Use standard part DIN5299-Type B

MATERIJAL: C15

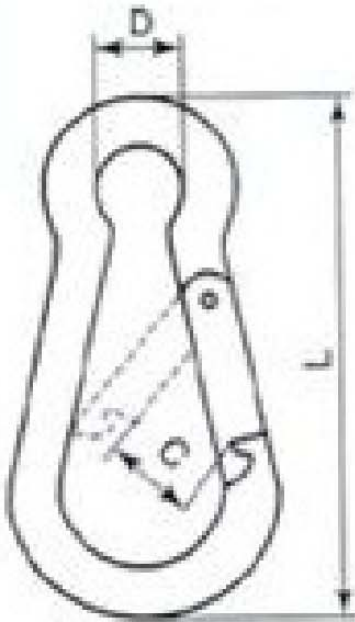

TIP B



TIP C

		L	D	C
27001	4	40	7	7

UNLESS OTHERWISE SPECIFIED: DIMENSIONS ARE IN MILLIMETERS SURFACE FINISH: TOLERANCES: IT12 LINEAR: ANGULAR:		FINISH:		DEBUR AND BREAK SHARP EDGES		DO NOT SCALE DRAWING		REVISION	
DRAWN		SIGNATURE		DATE		TITLE:			
CHK'D									
APPV'D									
MFG									
O.A				MATERIAL:		DWG NO.		A4	
						BSP-DIN5299-27001B			
				WEIGHT:		SCALE:1:1		SHEET 1 OF 1	